

# THREADING

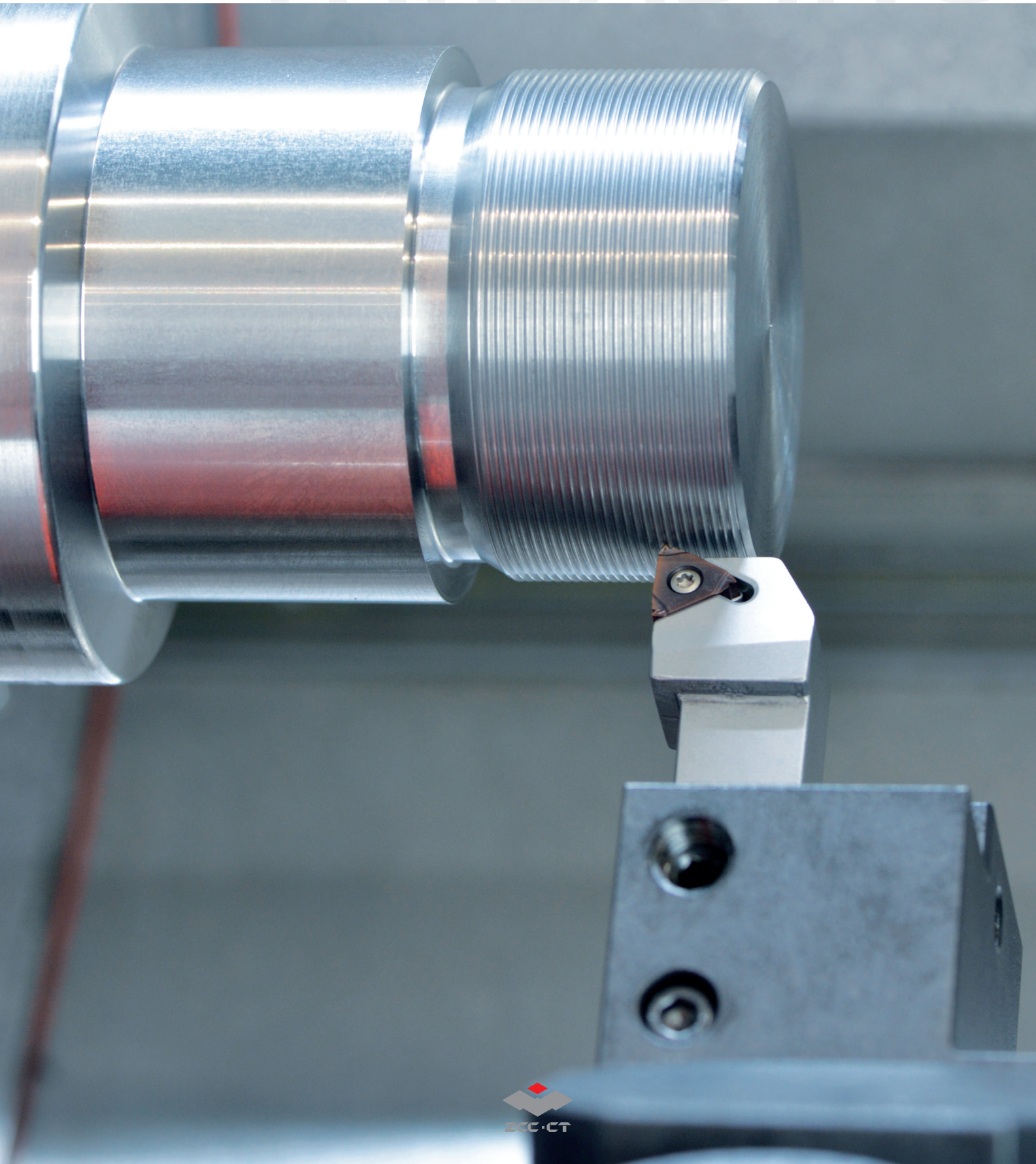

**A**

Turning

**B**

Milling

**C**

Drilling











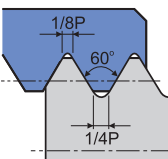

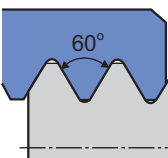

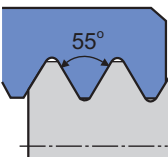

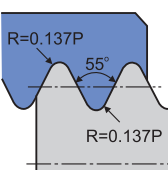
**D**Technical  
Information**E**

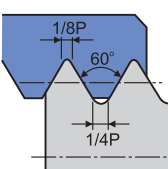

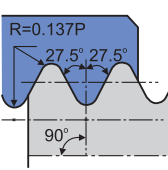

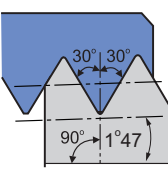

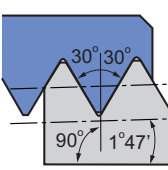



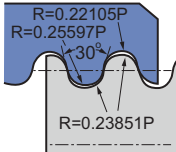

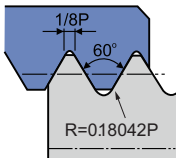

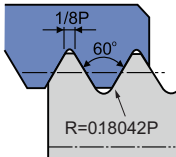

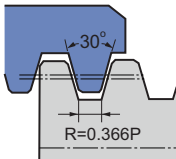
Index

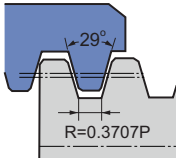
## Threading

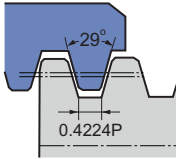
System overview	A460-A463
Grade overview	A464
Application fields of grades	A465
System code - inserts	A466
Inserts	A467-A491
System code - threading tool holders	A492
Threading tool holders	A493-A499
Recommended cutting data	A500
Trouble shooting	A504
Technical Information	A511-A512
Special tools	A513

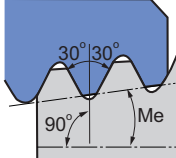

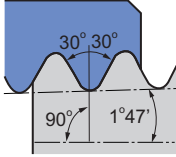
A	Thread types	Profile	Sectional drawing	Insert	Internal thread pitch mm (TPI)	External thread pitch mm (TPI)	Page
Turning	ISO metric coarse thread 60° full profile	GM			0,5-6,0	0,5-6,0	A467
	60° partial profile	60°			0,5-5,0 (5-48)	0,5-5,0 (5-48)	A469
Milling	55° partial profile	55°			0,5-5,0 (5-48)	0,5-5,0 (5-48)	A470
Drilling	Whitworth	W			(8-16)	(8-16)	A471
	UN unified conventional thread 60° full profile	UN			(8-20)	(8-20)	A472
Technical Information	BSPT Whitworth taper pipe thread	BSPT			(11-28)	11-28	A473
	NPT American taper pipe thread	NPT			(8-27)	(8-27)	A474
	NPTF dryseal American taper pipe thread 60°	NPTF			(8-27)	(8-27)	A475

Thread types	Profile	Sectional drawing	Insert	Internal thread pitch mm (TPI)	External thread pitch mm (TPI)	Page
R knuckle thread 30°	R			(6-10)	(6-10)	A476
MJ thread for aerospace	MJ			---	1,5-2,0	A477
UNJ unified screw thread	UNJ			---	(8-32)	A478
TR metrical ISO trapezoidal thread 30°	Tr			1,5-3,0	1,5-3,0	A479
ACME American national thread 29°	AC			(8-16)	(8-16)	A480
STUB-ACME thread	STAC			(8-16)	(8-16)	A481
API 60° thread	AP			4-5	(4-5)	A482
API round thread	RD			8-10	(8-10)	A483

<b>A</b>	Turning
<b>B</b>	Milling
<b>C</b>	Drilling
<b>D</b>	Technical Information
<b>E</b>	Index

**A**  
Turning

**B**  
Milling

**C**  
Drilling

**D**  
Technical Information

**E**  
Index

Thread types	Profile	Sectional drawing	Insert	Internal thread pitch mm (TPI)	External thread pitch mm (TPI)	Page
API American buttress thread	BUT			(5)	(5)	A484
ISO metric coarse thread 60° full profile (thin type)	GM			0,5-3,0	0,5-3,0	A485
60° partial profile (thin type)	60°			0,5-3,0 (8-48)	0,5-3,0 (8-48)	A486
55° partial profile (thin type)	55°			0,5-3,0 (8-48)	0,5-3,0 (8-48)	A487
Whitworth (thin type)	W			(8-16)	(8-16)	A488
UN unified conventional thread 60° full profile (thin type)	UN			(8-24)	(8-20)	A489
BSPT Whitworth taper pipe thread (thin type)	BSPT			(11-28)	(11-28)	A490
NPT American taper pipe thread (thin type)	NPT			(8-27)	(8-27)	A491

Type	Tool holder	Dimensions [mm]	Page
External thread holder		16×16×100 20×20×125 25×25×150 32×25×170 32×32×170 40×40×250	A493
Internal thread holder		16×125×12 16×150×16 16×150×20 20×150×25 20×180×25 25×150×32 32×200×40 32×250×40 40×300×50 50×350×63	A495
External thread holder (Thin Type)		16×16×100 32×25×170 20×20×125 32×32×170 25×25×150	A497
Internal thread holder (Thin Type)		16×150×20 32×200×40 20×180×25 32×250×40 25×150×32	A498

**A**

Turning

**B**

Milling

**C**

Drilling

**D**

Technical  
Information

**E**

Index

## Threading

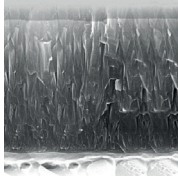
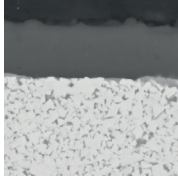
Grade	ISO	Micro structure	Grade description
<b>YBG201</b>	P10 - P30 M10 - M30		PVD coated P10–P30/M10–M30 carbide substrate for finishing to medium application of steel and stainless steel. Good wear resistance in a wide application field.
<b>YBG205</b>	P10 - P30 M20 - M40 S15-S25		PVD multilayer coated P10–P30/M20–M40/S15–S25 carbide substrate for finishing to medium machining of stainless steel, super alloys and steel (milling). Excellent wear resistance and thermal stability in a wide range of applications.

**A**

Turning

**B**

Milling

**C**

Drilling

**D**

Technical  
Information

**E**

Index

Application fields of grades – threading

	ISO	HC <sup>1</sup> (CVD)	HC <sup>1</sup> (PVD)	HT	HC <sup>2</sup>	Ceramic	HW	CBN	PCD
<b>P</b>	P01								
	P10		YBG205						
	P20								
	P30								
	P40								
<b>M</b>	M01								
	M10		YBG205						
	M20								
	M30								
	M40								
<b>K</b>	K01								
	K10								
	K20								
	K30								
<b>N</b>	N01								
	N10								
	N20								
	N30								
<b>S</b>	S01								
	S10		YBG205						
	S20								
	S30								
<b>H</b>	H01								
	H10								
	H20								
	H30								

<b>P</b>	Steel
<b>M</b>	Stainless steel
<b>K</b>	Cast iron

<b>N</b>	Non-ferrous metals
<b>S</b>	Heat-resistant alloys
<b>H</b>	Hardened materials

HC <sup>1</sup>	Coated carbide
HT	Uncoated cermet
HC <sup>2</sup>	Coated cermet
HW	Uncoated carbide

**A**

Turning

**B**

Milling

**C**

Drilling

**D**

Technical Information

**E**

Index



**R T 22. 01 W – 3.50 GM (P) (B)**

**1**

**2**

**3**

**4**

**5**

**6**

**7**

**8**

**9**

Type	
Code	Description
R	Right
L	Left

**1**

Insert shape	
T 	Z Special

**2**

Insert size [mm]	
Code	I.C
11	6,35
16	9,252
22	12,70

**3**

Teeth per cutting edge	
Code	Description
01	1
02	2

**4**

Application	
Code	Description
W	External thread
N	Internal thread

**5**

Pitch		
Code	Pitch range (part profile)	
A	0,5 – 1,5 mm	48 – 16 (TPI)
AG	0,5 – 3,0 mm	48 – 8 (TPI)
G	1,75 – 3,0 mm	14 – 8 (TPI)
N	3,5 – 5,0 mm	7 – 5 (TPI)
Pitch range [mm] (full profile)		
0,50 0,75 1,00 1,25 1,50		
1,75 2,00 2,50 3,00 3,50		
4,00 4,50 5,00 5,50 6,00		
Pitch range (TPI) (full profile)		
4 5 6 8		
10 11 11,5 12		
14 16 18 19		
20 24 27 28		

**6**

Thread profile	
Code	Description
GM	ISO metric coarse thread 60°
60	Partial profile 60°
55	Partial profile 55°
W	Whitworth
UN	Unified conventional thread
BSPT	Whitworth taper pipe thread
NPT	American taper pipe thread
NPTF	Dryseal American taper pipe thread
R	Knuckle thread 30°
MJ	Thread for aerospace
UNJ	Unified screw thread
TR	Metrical ISO trapezoidal thread
AC	American national thread
STAC	STUB-ACME thread
AP	API 60° thread
RD	API round thread
BUT	American buttress thread

**7**

Chip breaker
--------------

**8**

Insert thickness [mm]	
Code	Description
B	Thin type

**9**

**A**

Turning

**B**

Milling

**C**

Drilling

**D**

Technical Information

**E**

Index

R/LT**N/W	I.C	S	d
<b>11</b>	6.35	3.18	2.8
<b>16</b>	9.525	3.97	4.4
<b>22</b>	12.7	5.56	5.5

**Threading inserts**

ISO metric coarse thread 60° full profile

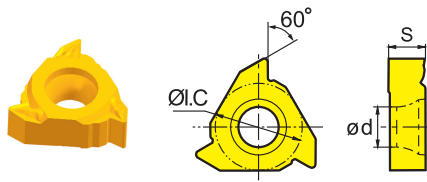

External right hand  
Internal left hand

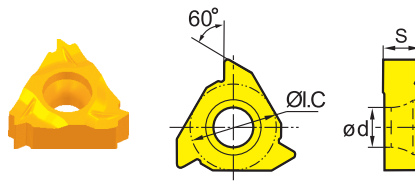

Internal right hand  
External left hand

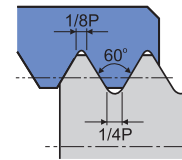

ISO 965-1980 DIN 13  
GB-T 197-2003 Tolerance: 6g-6H

ISO	Pitch (mm)	External	HC <sup>1</sup> (PVD)				Internal	HC <sup>1</sup> (PVD)			
			YBG201	YBG205				YBG201	YBG205		
11	0.50	-					RT11.01N-0.50GM	○			
11		-					LT11.01N-0.50GM	○			
11	0.75	-					RT11.01N-0.75GM	●			
11		-					LT11.01N-0.75GM	○			
11	1.00	-					RT11.01N-1.00GM	○ ●			
11		-					LT11.01N-1.00GM	●			
11	1.25	-					RT11.01N-1.25GM	●			
11		-					LT11.01N-1.25GM	●			
11	1.50	-					RT11.01N-1.50GM	○ ●			
11		-					LT11.01N-1.50GM	●			
11	1.75	-					RT11.01N-1.75GM	○			
11		-					LT11.01N-1.75GM	●			
11	2.00	-					RT11.01N-2.00GM	○ ●			
11		-					LT11.01N-2.00GM	●			
16	0.50	-					RT16.01N-0.50GM	○			
16		-					LT16.01N-0.50GM	○			
16	0.75	-					RT16.01N-0.75GM	○			
16		-					LT16.01N-0.75GM	○			
16	1.00	RT16.01W-1.00GM	○ ●				RT16.01N-1.00GM	○			
16		LT16.01W-1.00GM	●				LT16.01N-1.00GM	●			
16	1.25	RT16.01W-1.25GM	○ ●				RT16.01N-1.25GM	○			
16		LT16.01W-1.25GM	●				LT16.01N-1.25GM	●			
16	1.50	RT16.01W-1.50GM	○ ●				RT16.01N-1.50GM	●			
16		LT16.01W-1.50GM	●				LT16.01N-1.50GM	●			
16	1.75	RT16.01W-1.75GM	●				RT16.01N-1.75GM	○			
16		LT16.01W-1.75GM	●				LT16.01N-1.75GM	●			
16	2.00	RT16.01W-2.00GM	○ ●				RT16.01N-2.00GM	○ ●			

● Ex stock ○ On demand

HC<sup>1</sup> Coated carbide



**A**  
Turning  
**B**  
Milling  
**C**  
Drilling  
**D**  
Technical Information  
**E**  
Index

A

Turning

B

Milling

C

Drilling

D

Technical Information

E

Index

R/LT**N/W	I.C	S	d
<b>11</b>	6.35	3.18	2.8
<b>16</b>	9.525	3.97	4.4
<b>22</b>	12.7	5.56	5.5

## Threading inserts

### ISO metric coarse thread 60° full profile

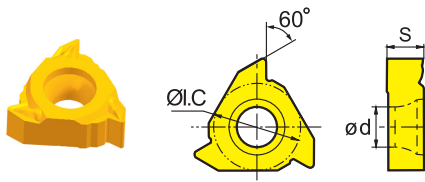

External right hand  
Internal left hand

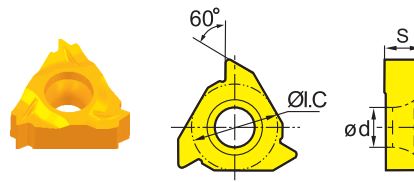

Internal right hand  
External left hand

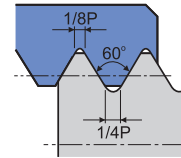



ISO 965-1980 DIN 13  
GB-T 197-2003 Tolerance: 6g-6H

ISO	Pitch (mm)	External	HC <sup>1</sup> (PVD)					Internal	HC <sup>1</sup> (PVD)					
			YBG201	YBG205					YBG201	YBG205				
16	2.00	LT16.01W-2.00GM	●					LT16.01N-2.00GM	●					
16	2.50	RT16.01W-2.50GM	○	●				RT16.01N-2.50GM	○	●				
16		LT16.01W-2.50GM	●					LT16.01N-2.50GM	●					
16	3.00	RT16.01W-3.00GM	○	●				RT16.01N-3.00GM	○	●				
16		LT16.01W-3.00GM	●					LT16.01N-3.00GM	●					
22	3.50	RT22.01W-3.50GM	○					RT22.01N-3.50GM	○	●				
22		LT22.01W-3.50GM	●					LT22.01N-3.50GM	●					
22	4.00	RT22.01W-4.00GM	○	●				RT22.01N-4.00GM	●					
22		LT22.01W-4.00GM	●					LT22.01N-4.00GM	●					
22	4.50	RT22.01W-4.50GM	○					RT22.01N-4.50GM	○	●				
22		LT22.01W-4.50GM	○					LT22.01N-4.50GM	●					
22	5.00	RT22.01W-5.00GM	○					RT22.01N-5.00GM	○					
22		LT22.01W-5.00GM	●					LT22.01N-5.00GM	●					
22	5.50	RT22.01W-5.50GM	○					RT22.01N-5.50GM	○					
22		LT22.01W-5.50GM	○					LT22.01N-5.50GM	●					
22	6.00	RT22.01W-6.00GM	○	●				RT22.01N-6.00GM	○	●				
22		LT22.01W-6.00GM	●					LT22.01N-6.00GM	●					

● Ex stock ○ On demand

HC<sup>1</sup> Coated carbide

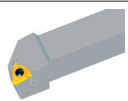
### Tool holders

SWR/L	SNR/L
	
A493-A494	A495-A496

System code > A466

Grade selection > A465

Technical info > A501

Cutting data > A500

Threading inserts

R/LT**N/W	I.C	S	d
<b>16</b>	9.525	3.97	4.4
<b>22</b>	12.7	5.56	5.5

60° partial profile

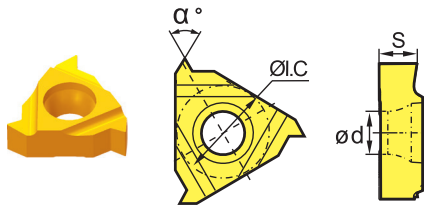

External right hand  
Internal left hand

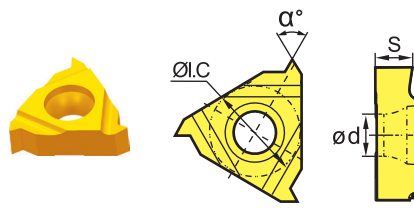

Internal right hand  
External left hand

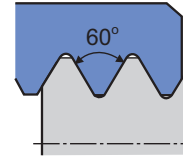



ISO	Pitch (mm)	External	HC <sup>1</sup> (PVD)					Internal	HC <sup>1</sup> (PVD)					
			YBG201	YBG205					YBG201	YBG205				
16	0.50 - 1.50	RT16.01W-A60	○	●				RT16.01N-A60	○					
16		LT16.01W-A60	●					LT16.01N-A60	●					
16	0.50 - 3.00	RT16.01W-AG60	○	●				RT16.01N-AG60	○					
16		LT16.01W-AG60	●					LT16.01N-AG60	●	●				
16	1.75 - 3.00	RT16.01W-G60	○					RT16.01N-G60	○					
16		LT16.01W-G60	●					LT16.01N-G60	○					
16		LT16.01W-G60P	●					LT16.01N-G60P	○					
16		RT16.01W-G60P*	○	○				RT16.01N-G60P*	○					
22	3.50 - 5.00	LT22.01W-N60P	○					-						
22		RT22.01W-N60P*	●					RT22.01N-N60P*	●					
22		LT22.01W-N60P*						LT22.01N-N60P*	○					

● Ex stock ○ On demand  
P\*: Inserts with chip-breakers

HC<sup>1</sup> Coated carbide

Tool holders

SWR/L	SNR/L
	
A493-A494	A495-A496

R/LT**N/W	I.C	S	d
<b>16</b>	9.525	3.97	4.4
<b>22</b>	12.7	5.56	5.5

## Threading inserts

### 55° partial profile

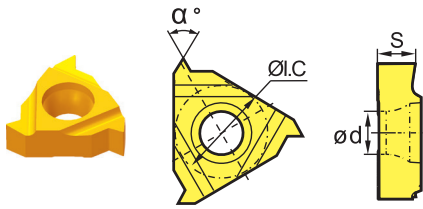

External right hand  
Internal left hand

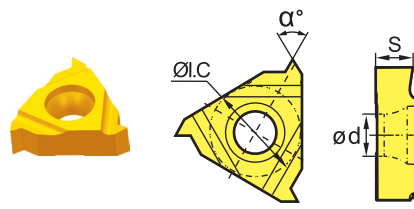

Internal right hand  
External left hand

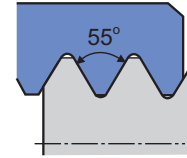



ISO	Pitch (T.Pi)	External	HC <sup>1</sup> (PVD)					Internal	HC <sup>1</sup> (PVD)					
			YBG201	YBG205						YBG201	YBG205			
16	48 - 16	RT16.01W-A55	○					RT16.01N-A55	○					
16		LT16.01W-A55	●					LT16.01N-A55	○					
16	48 - 8	RT16.01W-AG55	●					RT16.01N-AG55	○ ●					
16		LT16.01W-AG55	○					LT16.01N-AG55	●					
16	14 - 8	RT16.01W-G55	○					RT16.01N-G55	○					
16		LT16.01W-G55	●					LT16.01N-G55	○					
16		LT16.01W-G55P	●					LT16.01N-G55P	●					
16		RT16.01W-G55P*	○					RT16.01N-G55P*	○					
22	7 - 5	RT22.01W-N55P	○					RT22.01N-N55P	○					
22		-						LT22.01N-N55	○					

● Ex stock ○ On demand  
P\*: Inserts with chip-breakers

HC<sup>1</sup> Coated carbide

### Tool holders

SWR/L	SNR/L
	
A493-A494	A495-A496

System code > A466

Grade selection > A465

Technical info > A501

Cutting data > A500

Threading inserts

R/LT**N/W	I.C	S	d
<b>16</b>	9.525	3.97	4.4

Whitworth

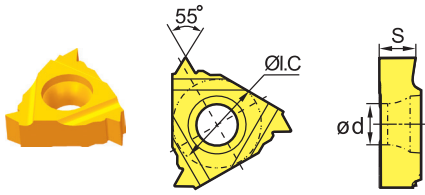

External right hand  
Internal left hand

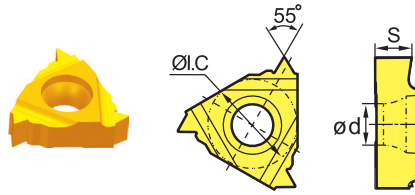

Internal right hand  
External left hand

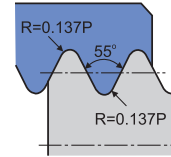



ISO 228-1:1982 DIN 259  
B.S.84: 1956 Tolerance: Medium Class 1

ISO	Pitch (T.P.i)	External	HC <sup>1</sup> (PVD)					Internal	HC <sup>1</sup> (PVD)					
			YBG201	YBG205					YBG201	YBG205				
16	8.00	RT16.01W-8W	○					RT16.01N-8W	○					
16		LT16.01W-8W	●					LT16.01N-8W	●					
16	9.00	-						RT16.01N-9W	○					
16		LT16.01W-9W	○					LT16.01N-9W	○					
16	10.00	RT16.01W-10W	○					RT16.01N-10W	○					
16		LT16.01W-10W	○					LT16.01N-10W	○					
16	11.00	RT16.01W-11W	○ ●					RT16.01N-11W	○ ●					
16		LT16.01W-11W	●					LT16.01N-11W	○					
16	12.00	RT16.01W-12W	○					RT16.01N-12W	○					
16		LT16.01W-12W	○					LT16.01N-12W	○					
16	14.00	RT16.01W-14W	●					RT16.01N-14W	○ ●					
16		LT16.01W-14W	○					LT16.01N-14W	○					
16	16.00	RT16.01W-16W	○ ●					RT16.01N-16W	○ ●					
16		LT16.01W-16W	○					LT16.01N-16W	○					

● Ex stock ○ On demand

HC<sup>1</sup> Coated carbide

Tool holders

SWR/L	SNR/L
	
A493-A494	A495-A496

System code > A466

Grade selection > A465

Technical info > A501

Cutting data > A500



A

Turning

B

Milling

C

Drilling

D

Technical Information

E

Index

R/LT**N/W	I.C	S	d
16	9.525	3.97	4.4

## Threading inserts

UN unified conventional thread 60° full profile

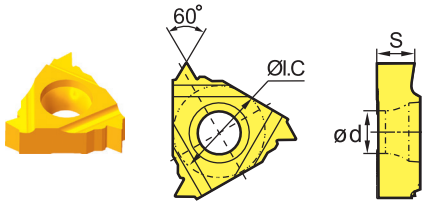

External right hand  
Internal left hand

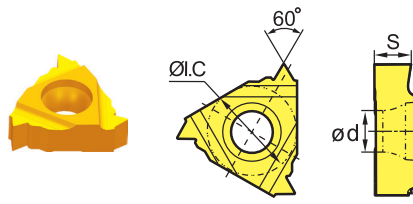

Internal right hand  
External left hand

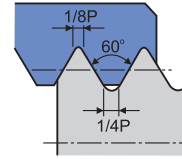

AS/E B1.1-1989  
Tolerance: 2A-2B

ISO	Pitch (T.Pi)	External	HC <sup>1</sup> (PVD)				Internal	HC <sup>1</sup> (PVD)			
			YBG201	YBG205				YBG201	YBG205		
16	8.00	RT16.01W-8UN	○				RT16.01N-8UN	○			
16		LT16.01W-8UN	○				LT16.01N-8UN	○			
16	10.00	RT16.01W-10UN	○				RT16.01N-10UN	○			
16		LT16.01W-10UN	○				LT16.01N-10UN	○			
16	12.00	RT16.01W-12UN	○				RT16.01N-12UN	○			
16		LT16.01W-12UN	○				LT16.01N-12UN	○			
16	14.00	RT16.01W-14UN	○				RT16.01N-14UN	○			
16		LT16.01W-14UN	○				LT16.01N-14UN	○			
16	16.00	RT16.01W-16UN	○				RT16.01N-16UN	○			
16		LT16.01W-16UN	○				LT16.01N-16UN	○			
16	18.00	RT16.01W-18UN	○				RT16.01N-18UN	○			
16		LT16.01W-18UN	○				LT16.01N-18UN	○			
16	20.00	RT16.01W-20UN	○				RT16.01N-20UN	○			
16		LT16.01W-20UN	○				LT16.01N-20UN	○			
16	24.00	-					RT16.01N-24UN	○			
16		-					LT16.01N-24UN	○			

● Ex stock ○ On demand

HC<sup>1</sup> Coated carbide

### Tool holders

SWR/L	SNR/L
A493-A494	A495-A496

System code > A466

Grade selection > A465

Technical info > A501

Cutting data > A500

Threading inserts

R/LT**N/W	I.C	S	d
<b>16</b>	9.525	3.97	4.4

BSPT Whitworth taper pipe thread

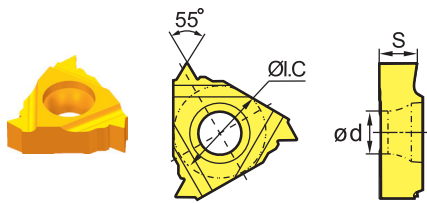

External right hand  
Internal left hand

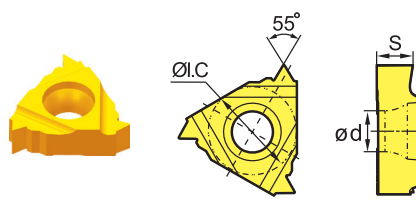

Internal right hand  
External left hand

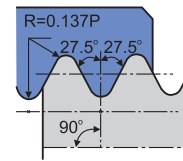



ISO 7-1: 1984 B.S.21:1985  
Standard BSPT

ISO	Pitch (T.P.i)	External	HC <sup>1</sup> (PVD)				Internal	HC <sup>1</sup> (PVD)			
			YBG201	YBG205				YBG201	YBG205		
16	11.00	RT16.01W-11BSPT	○				RT16.01N-11BSPT	○			
16		LT16.01W-11BSPT	●				LT16.01N-11BSPT	○			
16	14.00	RT16.01W-14BSPT	○				RT16.01N-14BSPT	○			
16		LT16.01W-14BSPT	○				LT16.01N-14BSPT	○			
16	19.00	RT16.01W-19BSPT	○				RT16.01N-19BSPT	○			
16		LT16.01W-19BSPT	○				LT16.01N-19BSPT	○			
16	28.00	RT16.01W-28BSPT	○				RT16.01N-28BSPT	○			
16		LT16.01W-28BSPT	○				LT16.01N-28BSPT	○			

● Ex stock ○ On demand

HC<sup>1</sup> Coated carbide

Tool holders

SWR/L	SNR/L
	
A493-A494	A495-A496



**A**

## Threading inserts

R/LT**N/W	I.C	S	d
16	9.525	3.97	4.4

Turning

### NPT American taper pipe thread

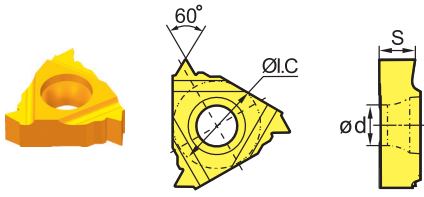

External right hand  
Internal left hand

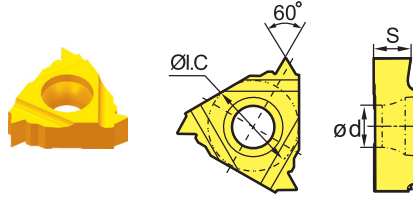

Internal right hand  
External left hand

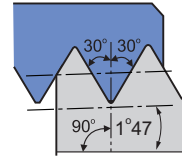

ASME B1.20.1-1983  
Standard NPT

**B**

Milling

ISO	Pitch (T.P.i)	External	HC <sup>1</sup> (PVD)				Internal	HC <sup>1</sup> (PVD)			
			YBG201	YBG205				YBG201	YBG205		
16	8.00	RT16.01W-8NPT	○				RT16.01N-8NPT	○			
16		LT16.01W-8NPT	○				LT16.01N-8NPT	○			
16	11.50	RT16.01W-11.5NPT	○				RT16.01N-11.5NPT	○			
16		LT16.01W-11.5NPT	○				LT16.01N-11.5NPT	○			
16	14.00	RT16.01W-14NPT	○	○			RT16.01N-14NPT	○			
16		LT16.01W-14NPT	○				LT16.01N-14NPT	○			
16	18.00	RT16.01W-18NPT	○				RT16.01N-18NPT	○			
16		LT16.01W-18NPT	○				LT16.01N-18NPT	○			
16	27.00	RT16.01W-27NPT	○				RT16.01N-27NPT	○			
16		LT16.01W-27NPT	○				LT16.01N-27NPT	○			

● Ex stock ○ On demand

HC<sup>1</sup> Coated carbide



**C**

Drilling

**D**

Technical Information

### Tool holders

SWR/L	SNR/L
	
A493-A494	A495-A496

**E**

Index

System code > A466

Grade selection > A465

Technical info > A501

Cutting data > A500

Threading inserts

R/LT**N/W	I.C	S	d
<b>16</b>	9.525	3.97	4.4

NPTF dryseal American taper pipe thread 60°

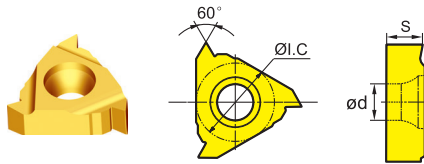

External right hand  
Internal left hand

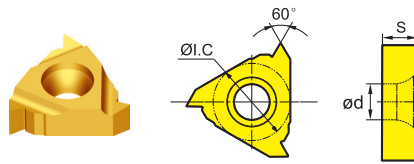

Internal right hand  
External left hand

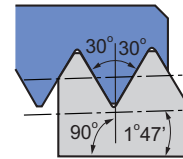



ASME B1.20.1-1983  
Tolerance: 2

ISO	Pitch (T.P.i)	External	HC <sup>1</sup> (PVD)					Internal	HC <sup>1</sup> (PVD)					
			YBG201	YBG205					YBG201	YBG205				
16	8.00	-												
16	11.50	RT16.01W-11.5NPTF	○					RT16.01N-11.5NPTF	○					
16	14.00	RT16.01W-14NPTF	○					RT16.01N-14NPTF	○					
16	18.00	RT16.01W-18NPTF	○					RT16.01N-18NPTF	○					
16	27.00	-						RT16.01N-27NPTF	○					

● Ex stock ○ On demand

HC<sup>1</sup> Coated carbide

Tool holders

SWR/L	SNR/L
	
A493	A495

System code > A466

Grade selection > A465

Technical info > A501

Cutting data > A500

**A**

## Threading inserts

R/LT**N/W	I.C	S	d
16	9.525	3.97	4.4

Turning

### R knuckle thread 30°

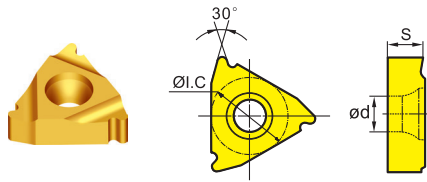

External right hand  
Internal left hand

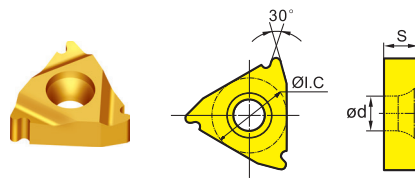

Internal right hand  
External left hand

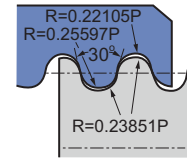

DIN 405  
Tolerance: 7

**B**

Milling

ISO	Pitch (T.P.i)	External	HC <sup>1</sup> (PVD)				Internal	HC <sup>1</sup> (PVD)			
			YBG201	YBG205				YBG201	YBG205		
16	6.00	RT16.01W-6R	○				RT16.01N-6R	○	○		
16	8.00	RT16.01W-8R	○				RT16.01N-8R	○	○		
16	10.00	RT16.01W-10R	○				RT16.01N-10R	○	○		



● Ex stock ○ On demand

HC<sup>1</sup> Coated carbide

**C**

Drilling

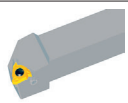
### Tool holders

SWR/L	SNR/L
	
A493	A495

**D**

Technical Information

**E**

Index

System code > A466

Grade selection > A465

Technical info > A501

Cutting data > A500

Threading inserts

R/LT**N/W	I.C	S	d
<b>16</b>	9.525	3.97	4.4

MJ thread for aerospace

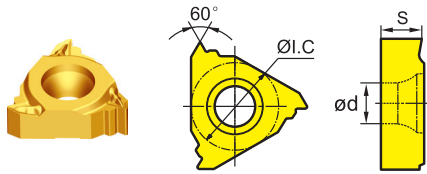

External right hand  
Internal left hand

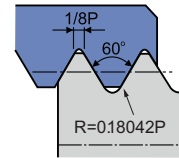

ISO 5855-1999  
Tolerance: 4

ISO	Pitch (mm)	External	HC <sup>1</sup> (PVD)					Internal	HC <sup>1</sup> (PVD)					
			YBG201	YBG205					YBG201	YBG205				
16	1.50	<b>RT16.01W-1.50MJ</b>	○					-						
16	2.00	<b>RT16.01W-2.00MJ</b>	○					-						

● Ex stock ○ On demand

HC<sup>1</sup> Coated carbide

Tool holders

SWR/L

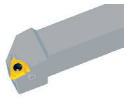

A493

A

Turning

B

Milling

C

Drilling

D

Technical Information

E

Index

**A**

## Threading inserts

R/LT**N/W	I.C	S	d
16	9.525	3.97	4.4

Turning

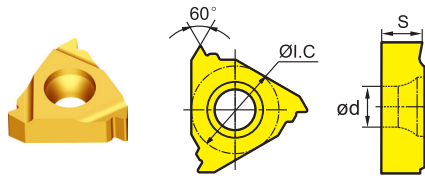

External right hand  
Internal left hand

### UNJ unified screw thread

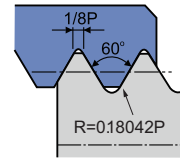

ISO 3161-1999  
Tolerance: 3A

**B**

Milling

ISO	Pitch (T.P.i)	External	HC <sup>1</sup> (PVD)					Internal	HC <sup>1</sup> (PVD)					
			YBG201	YBG205						YBG201	YBG205			
16	10.00	RT16.01W-10UNJ	○					-						
16	12.00	RT16.01W-12UNJ	○					-						
16	14.00	RT16.01W-14UNJ	○					-						
16	18.00	RT16.01W-18UNJ	○					-						
16	20.00	RT16.01W-20UNJ	○					-						
16	24.00	RT16.01W-24UNJ	○					-						
16	28.00	RT16.01W-28UNJ	○					-						
16	32.00	RT16.01W-32UNJ	○					-						

● Ex stock ○ On demand

HC<sup>1</sup> Coated carbide

**C**

Drilling

### Tool holders

SWR/L



A493

**D**

Technical Information

**E**

Index

System code > A466

Grade selection > A465

Technical info > A501

Cutting data > A500

Threading inserts

R/LT**N/W	I.C	S	d
<b>16</b>	9.525	3.97	4.4

TR metrical ISO trapezoidal thread 30°

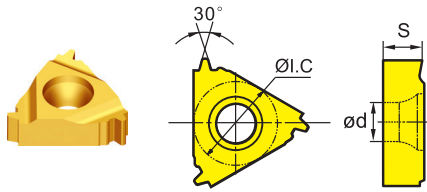

External right hand  
Internal left hand

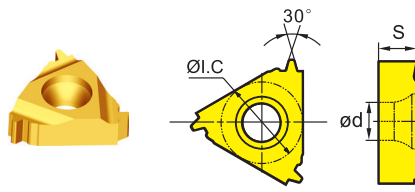

Internal right hand  
External left hand

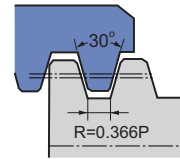



ISO 2901-2904  
Tolerance: 7

ISO	Pitch (mm)	External	HC <sup>1</sup> (PVD)					Internal	HC <sup>1</sup> (PVD)					
			YBG201	YBG205					YBG201	YBG205				
16	1.50	RT16.01W-1.50TR	○					●						
16	2.00	RT16.01W-2.00TR	○ ○					○ ○						
16	3.00	RT16.01W-3.00TR	○ ○					○ ●						

● Ex stock ○ On demand

HC<sup>1</sup> Coated carbide

Tool holders

SWR/L	SNR/L
	
A493	A495

A

Turning

B

Milling

C

Drilling

D

Technical Information

E

Index

R/LT**N/W	I.C	S	d
16	9.525	3.97	4.4

## Threading inserts

### ACME American national thread 29°

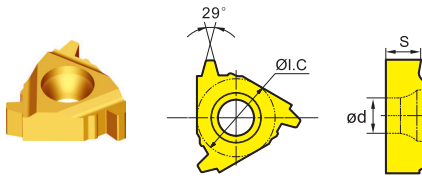

External right hand  
Internal left hand

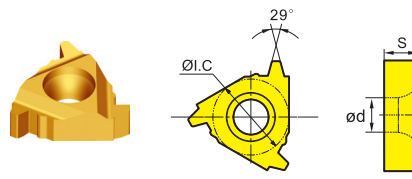

Internal right hand  
External left hand

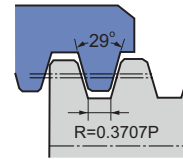



ANSI B1.5-1988  
Tolerance: 2G

ISO	Pitch (T.P.i)	External	HC <sup>1</sup> (PVD)				Internal	HC <sup>1</sup> (PVD)			
			YBG201	YBG205				YBG201	YBG205		
16	8.00	RT16.01W-8AC	○				RT16.01N-8AC	○			
16	10.00	RT16.01W-10AC	○				RT16.01N-10AC	○			
16	12.00	RT16.01W-12AC	○				RT16.01N-12AC	○			
16	14.00	RT16.01W-14AC	○				RT16.01N-14AC	○			
16	16.00	RT16.01W-16AC	○				RT16.01N-16AC	○			

● Ex stock ○ On demand

HC<sup>1</sup> Coated carbide

### Tool holders

SWR/L	SNR/L
	
A493	A495

A

Turning

B

Milling

C

Drilling

D

Technical Information

E

Index

System code > A466

Grade selection > A465

Technical info > A501

Cutting data > A500

Threading inserts

R/LT**N/W	I.C	S	d
<b>16</b>	9.525	3.97	4.4

STUB-ACME thread

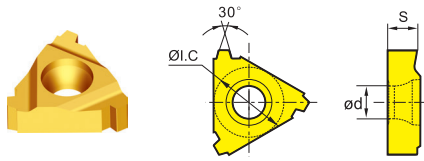

External right hand  
Internal left hand

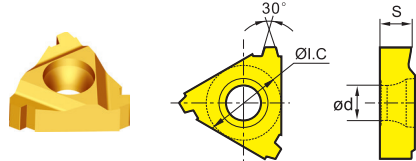

Internal right hand  
External left hand

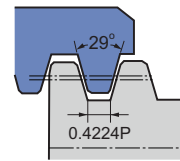



ANSI B1.8-1988  
Tolerance: API Standard

ISO	Pitch (T.P.i)	External	HC <sup>1</sup> (PVD)				Internal	HC <sup>1</sup> (PVD)			
			YBG201	YBG205				YBG201	YBG205		
16	8.00	RT16.01W-8STAC	○				RT16.01N-8STAC	○			
16	10.00	RT16.01W-10STAC	○				RT16.01N-10STAC	○			
16	12.00	RT16.01W-12STAC	○				RT16.01N-12STAC	○			
16	14.00	RT16.01W-14STAC	○				RT16.01N-14STAC	○			
16	16.00	RT16.01W-16STAC	○				RT16.01N-16STAC	○			

● Ex stock ○ On demand

HC<sup>1</sup> Coated carbide

Tool holders

SWR/L	SNR/L
	
A493	A495

System code > A466

Grade selection > A465

Technical info > A501

Cutting data > A500



A

## Threading inserts

R/LT**N/W	I.C	S	d
22	12.7	5.56	5.5

Turning

### API 60° thread

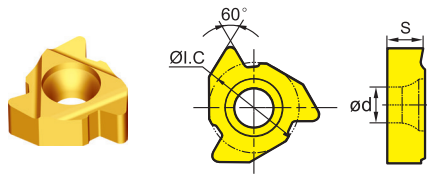

External right hand  
Internal left hand

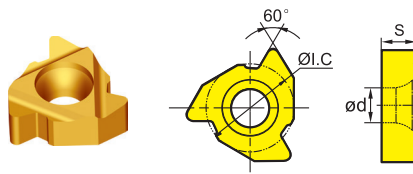

Internal right hand  
External left hand

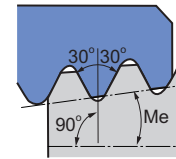

Me = taper, 2i.p.f-4°46', 3i.p.f-7°01'  
API SPEC7:1990 Tolerance: API Standard

B

Milling



ISO	Pitch (T.P.i)	External	HC <sup>1</sup> (PVD)				Internal	HC <sup>1</sup> (PVD)			
			YBG201	YBG205				YBG201	YBG205		
22	4.00	RT22.01W-4AP382	○				RT22.01N-4AP382	○			
22		RT22.01W-4AP383	○				RT22.01N-4AP383	○			
22		RT22.01W-4AP502	○				RT22.01N-4AP502	○			
22		RT22.01W-4AP503	○				RT22.01N-4AP503	○			
22	5.00	RT22.01W-5AP403	○				RT22.01N-5AP403	○			

● Ex stock ○ On demand

HC<sup>1</sup> Coated carbide

C

Drilling

Tool holders	
SWR/L	SNR/L
	
A493	A495

D

Technical Information

E

Index

System code > A466

Grade selection > A465

Technical info > A501

Cutting data > A500

**Threading inserts**

R/LT**N/W	I.C	S	d
<b>16</b>	9.525	3.97	4.4
<b>22</b>	12.7	5.56	5.5

**API round thread**

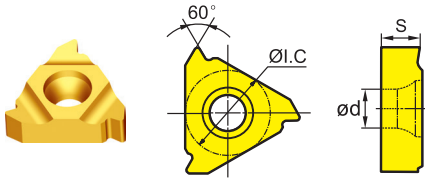

External right hand  
Internal left hand

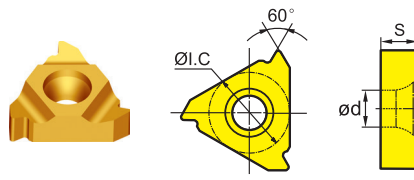

Internal right hand  
External left hand

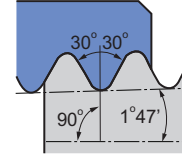



API spec.5B  
Tolerance: API RD

ISO	Pitch (T.P.i)	External	HC <sup>1</sup> (PVD)				Internal	HC <sup>1</sup> (PVD)			
			YBG201	YBG205				YBG201	YBG205		
16	8.00	RT16.01W-8RD	○				RT16.01N-8RD	○			
16	10.00	RT16.01W-10RD	○				RT16.01N-10RD	○			
22	8.00	RT22.01W-8RD	○				RT22.01N-8RD	○			
22	10.00	RT22.01W-10RD	○				RT22.01N-10RD	○			

● Ex stock ○ On demand

HC<sup>1</sup> Coated carbide

**Tool holders**

SWR/L	SNR/L
	
A493	A495

System code > A466

Grade selection > A465

Technical info > A501

Cutting data > A500



**A**

Turning

**B**

Milling

**C**

Drilling

**D**

Technical Information

**E**

Index

**A**

## Threading inserts

R/LT**N/W	I.C	S	d
<b>22</b>	12.7	5.56	5.5

Turning

### API American buttress thread

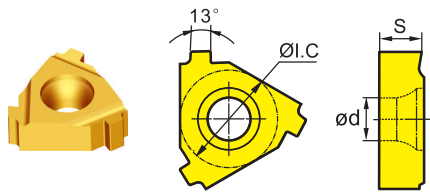

External right hand  
Internal left hand

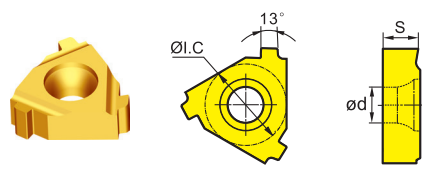

Internal right hand  
External left hand

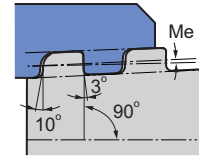

Me=taper 3/4i.p.f-1°47'-1°47' for Ø 4 1/2-13 3/8"  
1 i.p.f--2°23' for Ø16" SEPC.5B.1979 Tol.: API Std.

**B**

Milling

ISO	Pitch (T.P.i)	External	HC <sup>1</sup> (PVD)				Internal	HC <sup>1</sup> (PVD)			
			YBG201	YBG205				YBG201	YBG205		
22	5.00	RT22.01W-5BUT	○				RT22.01N-5BUT	○			



● Ex stock ○ On demand

HC<sup>1</sup> Coated carbide

**C**

Drilling

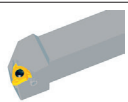
### Tool holders

SWR/L	SNR/L
	
A493	A495

**D**

Technical Information

**E**

Index

System code > A466

Grade selection > A465

Technical info > A501

Cutting data > A500

Threading inserts (thin type)

R/LT**N/W	I.C	S	d
<b>16</b>	9.525	3.52	4

ISO metric coarse thread 60° full profile (thin type)

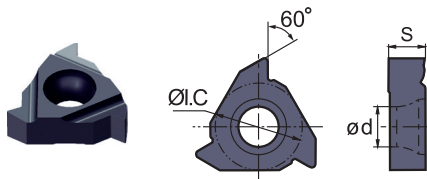

External right hand  
Internal left hand

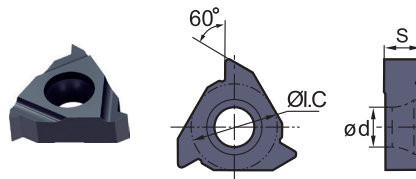

Internal right hand  
External left hand

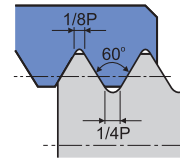



ISO 965-1980 DIN 13  
GB-T 197-2003 Tolerance: 6g/6H

ISO	Pitch (mm)	External	HC <sup>1</sup> (PVD)					Internal	HC <sup>1</sup> (PVD)					
			YBG202	YBG205					YBG202	YBG205				
16	0.50	RT16.01W-0.50GMB	○	○				RT16.01N-0.50GMB	○	○				
16	0.75	RT16.01W-0.75GMB	○	○				RT16.01N-0.75GMB	○	○				
16	1.00	RT16.01W-1.00GMB	○	○				RT16.01N-1.00GMB	○	○				
16		-						RT16.01N-1.00GMPB	○					
16	1.25	RT16.01W-1.25GMB	○	○				RT16.01N-1.25GMB	○	○				
16	1.50	RT16.01W-1.50GMB	○	○				RT16.01N-1.50GMB	○					
16		RT16.01W-1.50GMPB*	○	○				-						
16	1.75	RT16.01W-1.75GMB	○	○				RT16.01N-1.75GMB	○	○				
16	2.00	RT16.01W-2.00GMB	○	○				RT16.01N-2.00GMB	○	○				
16		-						RT16.01N-2.00GMPB*	○	○				
16	2.50	RT16.01W-2.50GMB	○	○				RT16.01N-2.50GMB	○	○				
16	3.00	RT16.01W-3.00GMB	○	○				RT16.01N-3.00GMB	○	○				
16		-						RT16.01N-3.00GMPB*	○					

● Ex stock ○ On demand  
PB\*: Inserts with chip-breakers

HC<sup>1</sup> Coated carbide

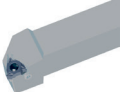
Tool holders

SWR	SNR
	
A497	A498

**A**

## Threading inserts (thin type)

R/LT**N/W	I.C	S	d
16	9.525	3.52	4

Turning

### 60° partial profile (thin type)

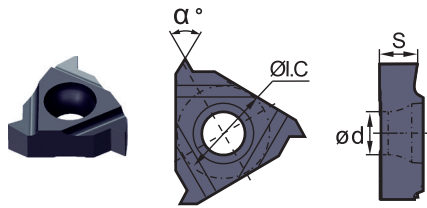

External right hand  
Internal left hand

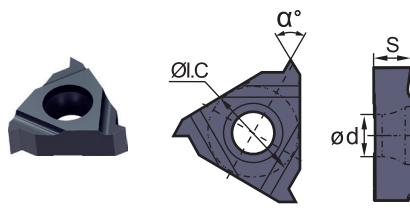

Internal right hand  
External left hand

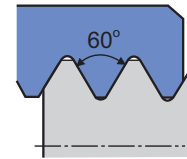

**B**

Milling

ISO	Pitch (mm)	External	HC <sup>1</sup> (PVD)				Internal	HC <sup>1</sup> (PVD)			
			YBG202	YBG205				YBG202	YBG205		
16	0.50 - 1.50	RT16.01W-A60B	○				RT16.01N-A60B	○			
16	0.50 - 3.00	RT16.01W-AG60B	○				RT16.01N-AG60B	○			
16		RT16.01W-AG60PB*	○				-				
16	1.75 - 3.00	RT16.01W-G60B	○				RT16.01N-G60B	○			



● Ex stock ○ On demand  
PB\*: Inserts with chip-breakers

HC<sup>1</sup> Coated carbide

**C**

Drilling

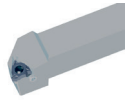
### Tool holders

SWR	SNR
	
A497	A498

**D**

Technical Information

**E**

Index

System code > A466

Grade selection > A465

Technical info > A501

Cutting data > A500

Threading inserts (thin type)

R/LT**N/W	I.C	S	d
<b>16</b>	9.525	3.52	4

55° partial profile (thin type)

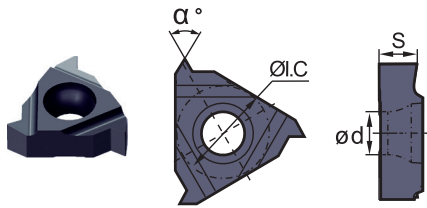

External right hand  
Internal left hand

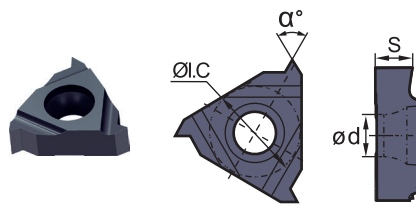

Internal right hand  
External left hand

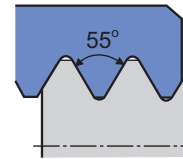



ISO	Pitch (T.P.i)	External	HC <sup>1</sup> (PVD)				Internal	HC <sup>1</sup> (PVD)			
			YBG202	YBG205				YBG202	YBG205		
16	48 - 16	RT16.01W-A55B	○				RT16.01N-A55B	○			
16	48 - 8	RT16.01W-AG55B	○				RT16.01N-AG55B	○			
16		RT16.01W-AG55PB	○	○			-				
16	14 - 8	RT16.01W-G55B	○				RT16.01N-G55B	○			

● Ex stock ○ On demand  
PB\*: Inserts with chip-breakers

HC<sup>1</sup> Coated carbide

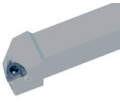
Tool holders

SWR	SNR
	
A497	A498

System code > A466

Grade selection > A465

Technical info > A501

Cutting data > A500

A

Turning

B

Milling

C

Drilling

D

Technical Information

E

Index

**A**

## Threading inserts (thin type)

R/LT**N/W	I.C	S	d
16	9.525	3.52	4

Turning

### Whitworth (thin type)

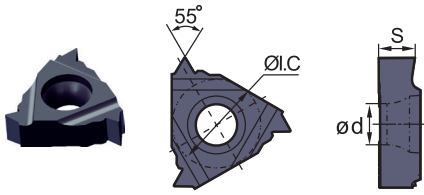

External right hand  
Internal left hand

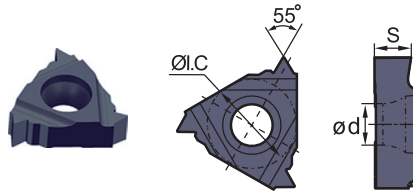

Internal right hand  
External left hand

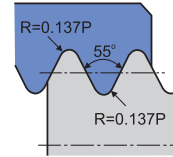

ISO 965-1980 DIN 13  
GB-T 197-2003 Tolerance: Medium Class A

**B**

Milling

ISO	Pitch (T.Pi)	External	HC <sup>1</sup> (PVD)					Internal	HC <sup>1</sup> (PVD)					
			YBG202	YBG205					YBG202	YBG205				
16	8.00	RT16.01W-8WB	○					RT16.01N-8WB	○					
16	9.00	RT16.01W-9WB	○					RT16.01N-9WB	○					
16	10.00	RT16.01W-10WB	○					RT16.01N-10WB	○					
16	11.00	RT16.01W-11WB	○	○				RT16.01N-11WB	○					
16		-						RT16.01N-11WPB	○					
16	12.00	RT16.01W-12WB	○					RT16.01N-12WB	○					
16		-						RT16.01N-12WPB*	○					
16	14.00	RT16.01W-14WB	○					RT16.01N-14WB	○					
16		-						RT16.01N-14WPB*	○					
16	16.00	RT16.01W-16WB	○					RT16.01N-16WB	○	○				

● Ex stock ○ On demand  
PB\*: Inserts with chip-breakers

HC<sup>1</sup> Coated carbide



**C**

Drilling

**D**

Technical Information

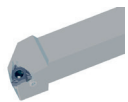
### Tool holders

SWR	SNR
	
A497	A498

**E**

Index

System code > A466

Grade selection > A465

Technical info > A501

Cutting data > A500

**Threading inserts (thin type)**

R/LT**N/W	I.C	S	d
<b>16</b>	9.525	3.52	4

**UN unified conventional thread 60° full profile (thin type)**

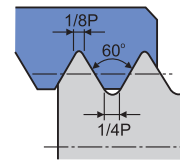
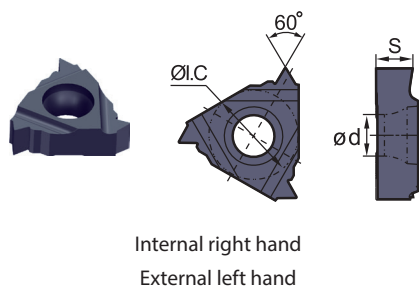
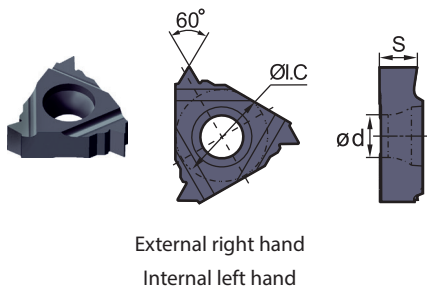



ASME B1.1-1989  
Tolerance: 2A/2B

ISO	Pitch (T.P.i)	External	HC <sup>1</sup> (PVD)				Internal	HC <sup>1</sup> (PVD)			
			YBG202	YBG205				YBG202	YBG205		
16	8.00	<b>RT16.01W-8UNB</b>	○				<b>RT16.01N-8UNB</b>	○			
16	10.00	<b>RT16.01W-10UNB</b>	○				<b>RT16.01N-10UNB</b>	○			
16	12.00	<b>RT16.01W-12UNB</b>	○				<b>RT16.01N-12UNB</b>	○			
16	14.00	<b>RT16.01W-14UNB</b>	○				<b>RT16.01N-14UNB</b>	○			
16	16.00	<b>RT16.01W-16UNB</b>	○				<b>RT16.01N-16UNB</b>	○			
16	18.00	<b>RT16.01W-18UNB</b>	○				<b>RT16.01N-18UNB</b>	○			
16	20.00	<b>RT16.01W-20UNB</b>	○				<b>RT16.01N-20UNB</b>	○			
16	24.00	-					<b>RT16.01N-24UNB</b>	○			

● Ex stock ○ On demand

HC<sup>1</sup> Coated carbide

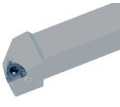
**Tool holders**

SWR	SNR
	
A497	A498



**A**

## Threading inserts (thin type)

R/LT**N/W	I.C	S	d
16	9.525	3.52	4

Turning

### BSPT Whitworth taper pipe thread (thin type)

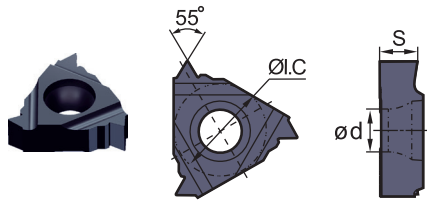

External right hand  
Internal left hand

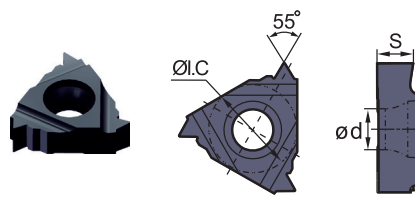

Internal right hand  
External left hand

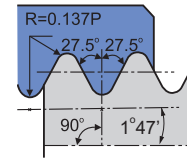

ASME B1.1-1989  
Standard BSPT

**B**

Milling

ISO	Pitch (T.Pi)	External	HC <sup>1</sup> (PVD)						Internal	HC <sup>1</sup> (PVD)							
			YBG202	YBG205						YBG202	YBG205						
16	11.00	RT16.01W-11BSPTB	○	○					RT16.01N-11BSPTB	○	○						
16	14.00	RT16.01W-14BSPTB	○						RT16.01N-14BSPTB	○							
16		RT16.01W-14BSPTPB*	○						RT16.01N-14BSPTPB*	○	○						
16	19.00	RT16.01W-19BSPTB	○						RT16.01N-19BSPTB	○							
16	28.00	RT16.01W-28BSPTB	○						RT16.01N-28BSPTB	○							

● Ex stock ○ On demand  
PB\*: Inserts with chip-breakers

HC<sup>1</sup> Coated carbide

**C**

Drilling

Tool holders	
SWR	SNR
A497	A498

**D**

Technical Information

**E**

Index

System code > A466

Grade selection > A465

Technical info > A501

Cutting data > A500

**Threading inserts (thin type)**

R/LT**N/W	I.C	S	d
<b>16</b>	9.525	3.52	4

**NPT American taper pipe thread (thin type)**

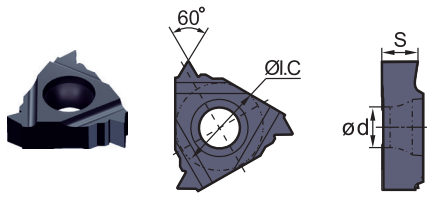

External right hand  
Internal left hand

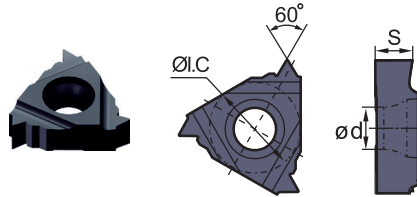

Internal right hand  
External left hand

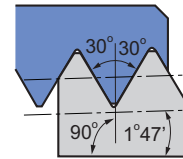



ASME B1.20.1-1983  
Standard NPT

ISO	Pitch (T.P.i)	External	HC <sup>1</sup> (PVD)					Internal	HC <sup>1</sup> (PVD)					
			YBG202	YBG205						YBG202	YBG205			
16	8.00	RT16.01W-8NPTB	○					RT16.01N-8NPTB	○					
16	11.50	RT16.01W-11.5NPTB	○					RT16.01N-11.5NPTB	○					
16		-						RT16.01N-11.5NPTPB*	○					
16	14.00	RT16.01W-14NPTB	○	○				RT16.01N-14NPTB	○					
16		-						RT16.01N-14NPTPB*	○	○				
16	18.00	RT16.01W-18NPTB	○					RT16.01N-18NPTB	○					
16	27.00	RT16.01W-27NPTB	○					RT16.01N-27NPTB	○					

● Ex stock ○ On demand  
PB\*: Inserts with chip-breakers

HC<sup>1</sup> Coated carbide

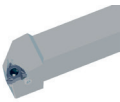
**Tool holders**

SWR	SNR
	
A497	A498

**S W R 20 20 K 16 (B)**

1

2

3

4

5



6

7

8

**A**

Turning

Clamping system	
Code	Description
S	Screw clamping 
C	Top clamping 

Application	
Code	Description
W	External thread tool holder
N	Internal thread tool holder

**B**

Milling

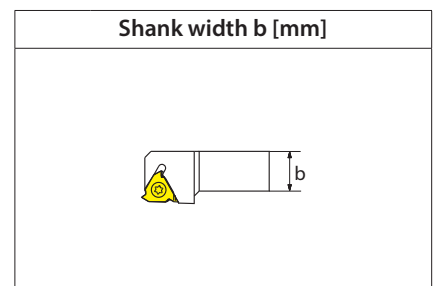
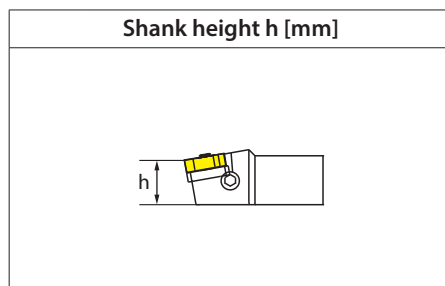
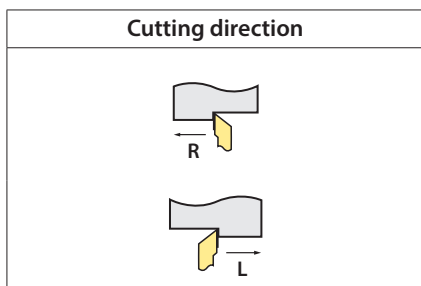

**C**

Drilling

Shank length L [mm]	
Code	L
H	100
K	125
M	150
P	170
Q	180
R	200
S	250
T	300

Insert size [mm]	
Code	Height
11	6,35
16	9,525
22	12,7

**D**

Technical Information

Holder for thin thread inserts  
(B type)

**E**

Index

### Threading tool holder (external)

SWR/L

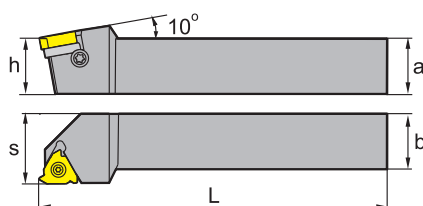
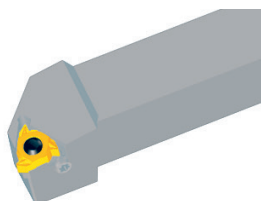

Article	*	Stock	Dimensions [mm]					Inserts
			a	b	L	h	s	
SWR1616H16		●	16	16	100	16	20	RT16.01W-****
SWR2020K16		●	20	20	125	20	25	RT16.01W-****
SWR2525M16		●	25	25	150	25	32	RT16.01W-****
SWR3225P16		●	32	25	170	32	32	RT16.01W-****
SWR3232P16		●	32	32	170	32	40	RT16.01W-****
SWR2525M22		●	25	25	150	25	32	RT22.01W-****
SWR3225P22		●	32	25	170	32	32	RT22.01W-****
SWR3232P22		●	32	32	170	32	40	RT22.01W-****
SWR4040S22		○	40	40	250	40	50	RT22.01W-****

● Ex stock   ○ On demand

\* With internal cooling

Spare parts			
	Insert	RT16.01W-****	RT22.01W-****
	h	16-32	25-40
	Screw	I60M3.5x12 (2.7 Nm)	I60M5x17 (6.7 Nm)
	Screw (shim)	SM4x8C	SM5x8.5C
	Shim	MT16-__M	MT22-__M
	Wrench (screw)	WT15IP	WT20IP

Insert



Medium Cut  
A467

System code > A492

Grade selection > A465

Technical info > A501

Cutting data > A500



A

Turning

B

Milling

C

Drilling

D

Technical Information

E

Index

### Threading tool holder (external)

SWR/L

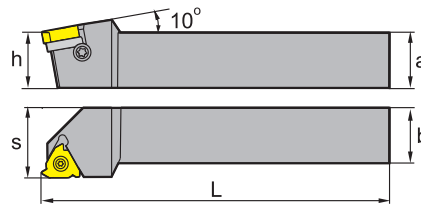
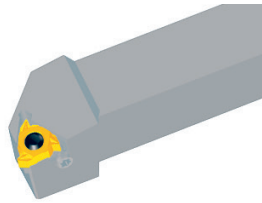

Article	*	Stock	Dimensions [mm]					Inserts
			a	b	L	h	s	
SWL1616H16		●	16	16	100	16	20	LT16.01W-****
SWL2020K16		●	20	20	125	20	25	LT16.01W-****
SWL2525M16		●	25	25	150	25	32	LT16.01W-****
SWL3225P16		●	32	25	170	32	32	LT16.01W-****
SWL3232P16		○	32	32	170	32	40	LT16.01W-****
SWL2525M22		●	25	25	150	25	32	LT22.01W-****
SWL3225P22		○	32	25	170	32	32	LT22.01W-****
SWL3232P22		●	32	32	170	32	40	LT22.01W-****
SWL4040S22		○	40	40	250	40	50	LT22.01W-****

● Ex stock ○ On demand

\* With internal cooling

Spare parts			
	Insert	LT16.01W-****	LT22.01W-****
	h	16-32	25-40
	Screw	I60M3.5×12 (2.7 Nm)	I60M5×17 (6.7 Nm)
	Screw (shim)	SM4×8C	SM5×8.5C
	Shim	MT16-__M	MT22-__M
	Wrench (screw)	WT15IP	WT20IP

Insert
Medium Cut
A467

System code > A492

Grade selection > A465

Technical info > A501

Cutting data > A500

### Threading tool holder (internal)

SNR/L

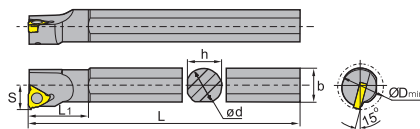

Article	*	Stock	Dimensions [mm]							Inserts
			ød	b	L	h	s	L <sub>1</sub>	D <sub>min</sub>	
SNR0016K11	●	●	16	16	125	15	10	20.9	12	RT11.01N-****
SNR0016M11	●	●	16	15.5	150	15	10.5	25.9	16	RT11.01N-****
SNR0016M16	●	●	16	15.5	150	15	12	27	20	RT16.01N-****
SNR0020M16	●	●	20	19	150	18	14	28.7	25	RT16.01N-****
SNR0020Q16	●	●	20	19	180	18	14	34	25	RT16.01N-****
SNR0025M16	●	●	25	24	150	23	17	28.8	32	RT16.01N-****
SNR0032R16	●	●	32	31	200	30	22	30.9	40	RT16.01N-****
SNR0032S16	●	●	32	31	250	30	22	30.9	40	RT16.01N-****
SNR0040T16	●	●	40	38.5	300	37	27	31.5	50	RT16.01N-****
SNR0050U16	○	○	50	49.5	350	49	35	40.2	63	RT16.01N-****
SNR0020Q22	●	●	20	21.5	180	18	15	35	25	RT22.01N-****
SNR0025R22	●	●	25	24	200	23	19	39	32	RT22.01N-****
SNR0032S22	●	●	32	31	250	30	22	36.4	40	RT22.01N-****
SNR0040T22	●	●	40	38.5	300	37	27	37.2	50	RT22.01N-****
SNR0050U22	●	●	50	48.5	350	47	35	42.6	63	RT22.01N-****

● Ex stock ○ On demand

\* With internal cooling

Spare parts						
	Insert	RT11.01N-****	RT16.01N-****	RT16.01N-****	RT22.01N-****	RT22.01N-****
	ød	16	16	20-50	20	25-50
	Screw	I60M2.5x6.5 (1.0 Nm)	I60M3.5x8 (2.7 Nm)	I60M3.5x12 (2.7 Nm)	I60M5x10 (6.7 Nm)	I60M5x17 (6.7 Nm)
	Screw (shim)			SM4x8C		SM5x8.5C
	Shim			MT16-__M		MT22-__M
	Wrench (screw)	WT07IP	WT15IP	WT15IP	WT20IP	WT20IP

Insert



Medium Cut

A467

System code > A492

Grade selection > A465

Technical info > A501

Cutting data > A500



### Threading tool holder (internal)

SNR/L

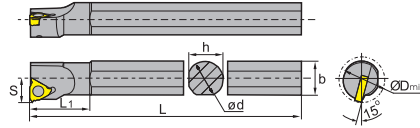

Article	*	Stock	Dimensions [mm]								Inserts
			ød	b	L	h	s	L <sub>1</sub>	D <sub>min</sub>		
SNL0016K11	●	●	16	16	125	15	10	20.9	12	LT11.01N-****	
SNL0016M11	●	●	16	15.5	150	15	10.5	25.9	16	LT11.01N-****	
SNL0016M16	●	●	16	15.5	150	15	12	27	20	LT16.01N-****	
SNL0020M16	○	○	20	19	150	18	14	28.7	25	LT16.01N-****	
SNL0020Q16	●	●	20	19	180	18	14	34	25	LT16.01N-****	
SNL0025M16	●	●	25	24	150	23	17	28.8	32	LT16.01N-****	
SNL0032R16	●	●	32	31	200	30	22	30.9	40	LT16.01N-****	
SNL0032S16	○	○	32	31	250	30	22	30.9	40	LT16.01N-****	
SNL0040T16	●	●	40	38.5	300	37	27	31.5	50	LT16.01N-****	
SNL0050U16	○	○	50	49.5	350	49	35	40.2	63	LT16.01N-****	
SNL0020Q22	●	●	20	21.5	180	18	15	35	25	LT22.01N-****	
SNL0025R22	○	○	25	24	200	23	19	39	32	LT22.01N-****	
SNL0032S22	●	●	32	31	250	30	22	36.4	40	LT22.01N-****	
SNL0040T22	●	●	40	38.5	300	37	27	37.2	50	LT22.01N-****	
SNL0050U22	●	●	50	48.5	350	47	35	42.6	63	LT22.01N-****	

● Ex stock ○ On demand

\* With internal cooling

Spare parts						
	Insert	LT11.01N-****	LT16.01N-****	LT16.01N-****	LT22.01N-****	LT22.01N-****
	ød	16	16	20-50	20	25-50
	Screw	I60M2.5×6.5 (1.0 Nm)	I60M3.5×8 (2.7 Nm)	I60M3.5×12 (2.7 Nm)	I60M5×10 (6.7 Nm)	I60M5×17 (6.7 Nm)
	Screw (shim)			SM4×8C		SM5×8.5C
	Shim			MT16-__M		MT16-__M
	Wrench (screw)	WT07IP	WT15IP	WT15IP	WT20IP	WT20IP

Insert



**Medium Cut**  
A467

System code > A492

Grade selection > A465

Technical info > A501

Cutting data > A500

### Threading tool holder (external)

#### SWR-B Thin Type

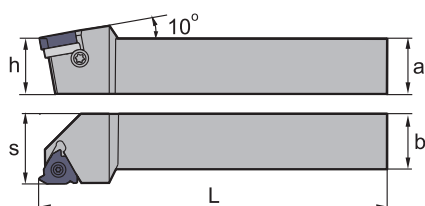
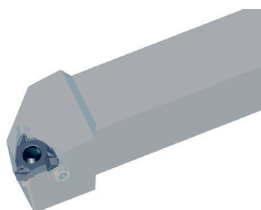

Article	*	Stock	Dimensions [mm]					Inserts
			a	b	L	h	s	
SWR1616H16B		●	16	16	100	16	20	RT16.01W-****B
SWR2020K16B		●	20	20	125	20	25	RT16.01W-****B
SWR2525M16B		●	25	25	150	25	32	RT16.01W-****B
SWR3225P16B		●	32	25	170	32	32	RT16.01W-****B
SWR3232P16B		●	32	32	170	32	40	RT16.01W-****B

● Ex stock   ○ On demand

\* With internal cooling

Spare parts		
	Insert	RT16.01W-****B
	h	16-32
	Screw	I60M3.5x12TT (2.7 Nm)
	Screw (shim)	SM4x8C
	Shim	MT16-__M
	Wrench (screw)	WT15IP

Insert
<b>Medium Cut</b>
A486

System code > A492

Grade selection > A465

Technical info > A501

Cutting data > A500



A

### Threading tool holder (internal)

SNR-B Thin Type

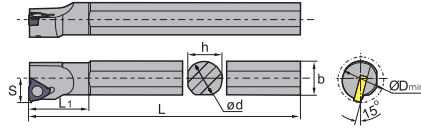
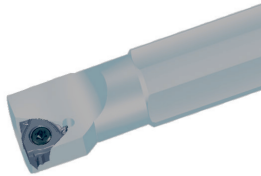

Turning

B

Article	*	Stock	Dimensions [mm]							Inserts
			ød	b	L	h	s	L <sub>1</sub>	D <sub>min</sub>	
SNR0016M16B	●		16	15.5	150	15	12	27	20	RT16.01N-****B
SNR0020Q16B	●		20	19	180	18	14	34	25	RT16.01N-****B
SNR0025M16B	●		25	24	150	23	17	28.8	32	RT16.01N-****B
SNR0032R16B	●		32	31	200	30	22	30.9	40	RT16.01N-****B
SNR0032S16B	●		32	31	250	30	22	30.9	40	RT16.01N-****B

● Ex stock ○ On demand

\* With internal cooling

Milling

C

Spare parts			
	Insert	RT16.01N-****B	RT16.01N-****B
	ød	16	20-32
	Screw	I60M3.5x08TT (2.7 Nm)	
	Screw		I60M3.5x12TT (2.7 Nm)
	Screw (shim)		SM4x8C
	Shim		MT16-__M
	Wrench (screw)	WT15IP	WT15IP

Drilling

D

Technical Information

E

Index

System code > A492

Grade selection > A465

Technical info > A501

Cutting data > A500



## Threading inserts

Material group	Composition / structure / heat treatment		Brinell hardness HB	Machining group	Starting values for cutting speed $v_c$ [m/min]			
					HC (PVD)			
					YBG201	YBG205		
<b>P</b> Unalloyed steel  Low-alloyed steel  High-alloyed steel and high-alloyed tool steel	approx. 0,15 % C	annealed	125	1	190	190		
		annealed	190	2	175	175		
		tempered	250	3	145	145		
		annealed	270	4	140	140		
	approx. 0,45 % C	annealed	270	4	140	140		
		tempered	300	5	135	135		
	annealed		180	6	170	170		
		tempered	275	7	125	125		
		tempered	300	8	115	115		
	tempered		350	9	105	105		
annealed		200	10	125	125			
hardened and tempered		325	11	95	95			
<b>M</b> Stainless steel	ferritic/martensitic	annealed	200	12	165	165		
	martensitic	tempered	240	13	135	135		
	austenitic	quench hardened	180	14	155	155		
	austenitic-ferritic		230	15	135	135		
<b>K</b> Grey cast iron  Cast iron with spheroidal graphite  Malleable cast iron	perlitic/ferritic		180	16	240	240		
		perlitic (martensitic)	260	17	185	185		
	ferritic		160	18	220	220		
		perlitic	250	19	165	165		
ferritic		130	20	175	175			
	perlitic	230	21	165	165			
<b>N</b> Aluminium wrought alloys  Cast aluminium alloys  Copper and copper alloys (bronze/brass)	cannot be hardened		60	22	800	800		
	hardenable	hardened	100	23	600	600		
	$\leq 12\% \text{ Si}$ , cannot be hardened		75	24	320	320		
		$\leq 12\% \text{ Si}$ , hardenable	hardened	90	25	240	240	
		$> 12\% \text{ Si}$ , cannot be hardened		130	26	160	160	
	machining steel, PB > 1%		110	27	160	160		
CuZn, CuSnZn		90	28	600	600			
CuSn, Pb-free copper, electrolytic copper		100	29	200	200			
<b>S</b> Heat-resistant alloys  Titanium alloys	Fe-based alloys	annealed	200	30	95	95		
		hardened	280	31	50	50		
		annealed	250	32	80	80		
		hardened	350	33	70	70		
	Ni or Co bass	cast	320	34	70	70		
pure titanium		$R_m 400$	35	145	145			
$\alpha$ and $\beta$ alloys	hardened	$R_m 1050$	36	50	50			
<b>H</b> Hardened steel  Hard cast iron  Hardened cast iron		hardened and tempered	55 HRC	37				
		hardened and tempered	60 HRC	38				
		cast	400	39				
<b>X</b> Non-metallic materials		hardened and tempered	55 HRC	40				
	Thermoplasts			41				
	Thermosetting plastics			42				
	Plastic, glass-fibre reinforced GFRP			43				
	Plastic, carbon fibre reinforced CFRP			44				
Graphite			45					
Wood			46					

Note: The given cutting values are guide values, which were determined under ideal conditions.  
The values have to be adapted in individual cases.  
For examples of material for cutting tool groups view page D11.

HC Coated carbide

## Technical information

Trouble shooting - turning

A502-A504

Technical Information - turning

A505-A512

Special tools – turning

A513

# A

**A**

Turning

**B**

Milling

**C**

Drilling

**D**

Technical  
Information

**E**

Index

## Trouble shooting – general turning

Fig.	Type of wear	Effects	Reason	Countermeasure
1+2	Flank wear	<ul style="list-style-type: none"> <li>– Bad surface quality and dimensional stability</li> <li>– Increase of cutting force</li> </ul>	<ul style="list-style-type: none"> <li>– Grade not wear-resistant enough</li> <li>– Cutting speed too high</li> <li>– Clearance angle too small</li> <li>– Feed rate too low</li> </ul>	<ul style="list-style-type: none"> <li>– Grade with higher wear-resistance</li> <li>– Reduce cutting speed</li> <li>– Increase clearance angle</li> <li>– Reduce feed rate</li> </ul>
3	Crater wear	<ul style="list-style-type: none"> <li>– Bad surface quality and chip control</li> </ul>	<ul style="list-style-type: none"> <li>– Grade not wear-resistant enough</li> <li>– Cutting speed too high</li> <li>– Feed rate too low</li> </ul>	<ul style="list-style-type: none"> <li>– Grade with higher wear-resistance</li> <li>– Reduce cutting speed</li> <li>– Reduce feed rate</li> </ul>
4	Chipping	<ul style="list-style-type: none"> <li>– Unstable tool life</li> <li>– Sudden breakage of cutting edge</li> </ul>	<ul style="list-style-type: none"> <li>– Grade too hard</li> <li>– Feed rate too high</li> <li>– Cutting edge not stable enough</li> <li>– Stability of the holder or tension insufficient</li> </ul>	<ul style="list-style-type: none"> <li>– Grade with higher toughness</li> <li>– Reduce feed rate</li> <li>– Change honing of cutting edge</li> <li>– Use a more stable tool holder</li> </ul>
5	Breakage	<ul style="list-style-type: none"> <li>– Increase of cutting force</li> <li>– Bad surface quality and dimensional stability</li> </ul>	<ul style="list-style-type: none"> <li>– Grade too hard</li> <li>– Feed rate too high</li> <li>– Cutting edge not stable enough</li> <li>– Stability of the holder or tension insufficient</li> </ul>	<ul style="list-style-type: none"> <li>– Grade with higher toughness</li> <li>– Reduce feed rate</li> <li>– Change honing of cutting edge</li> <li>– Use a more stable tool holder</li> </ul>
6	Plastic deformation	<ul style="list-style-type: none"> <li>– Bad dimensional stability</li> <li>– Damage to cutting edge</li> </ul>	<ul style="list-style-type: none"> <li>– Grade not wear-resistant enough</li> <li>– Cutting speed too high</li> <li>– Cutting depth and/or feed rate too high</li> <li>– Temperature on the cutting edge too high</li> </ul>	<ul style="list-style-type: none"> <li>– Grade with higher toughness</li> <li>– Reduce cutting speed</li> <li>– Reduce cutting depth and feed rate</li> <li>– Grade with higher heat-resistance</li> </ul>
7	Welding	<ul style="list-style-type: none"> <li>– Increase of cutting force</li> <li>– Bad surface quality</li> </ul>	<ul style="list-style-type: none"> <li>– Cutting speed too low</li> <li>– Cutting edge not sharp enough</li> <li>– Grade not suitable</li> </ul>	<ul style="list-style-type: none"> <li>– Increase cutting speed</li> <li>– Increase rake angle</li> <li>– Use a more suitable grade</li> </ul>
8	Thermal cracks	<ul style="list-style-type: none"> <li>– Breakage due to thermal interaction, often caused when cutting is interrupted (milling)</li> </ul>	<ul style="list-style-type: none"> <li>– Temperature fluctuation when machining</li> <li>– Grade too hard</li> </ul>	<ul style="list-style-type: none"> <li>– Dry machining</li> <li>– Grade with higher toughness</li> </ul>
9	Notch wear	<ul style="list-style-type: none"> <li>– Burr formation</li> <li>– Increase of cutting force</li> </ul>	<ul style="list-style-type: none"> <li>– Damage through chips (jagged edges)</li> <li>– Feed rate and cutting speed too high</li> </ul>	<ul style="list-style-type: none"> <li>– Grade with higher wear-resistance</li> <li>– Increase rake angle to get a sharper cutting edge</li> <li>– Reduce cutting speed</li> </ul>
10	Flaking (coating)	<ul style="list-style-type: none"> <li>– Often appears when machining hardened materials or caused by vibration</li> </ul>	<ul style="list-style-type: none"> <li>– Cutting edge adhesion and chipping</li> <li>– Bad chip removal</li> </ul>	<ul style="list-style-type: none"> <li>– Increase rake angle to get a sharper cutting edge</li> <li>– Chip breaker with bigger chip space</li> </ul>

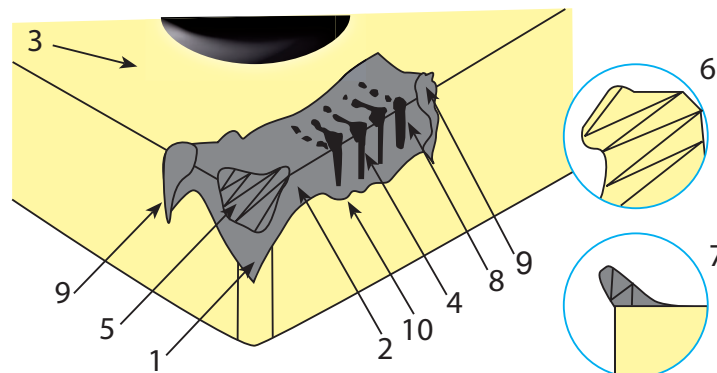

A

Turning

B

Milling

C

Drilling

D

Technical Information

E

Index

**Trouble shooting – PCBN & PCD**

Type of wear	Countermeasure	
	Geometry	Cutting condition
Flank wear	<ul style="list-style-type: none"> <li>- Sharper cutting edge for reduced cutting force</li> <li>- Smaller negative chamfer</li> <li>- Use positive inserts</li> </ul>	<ul style="list-style-type: none"> <li>- Reduce cutting speed</li> <li>- Increase feed rate to reduce operation time</li> </ul>
Notch wear	<ul style="list-style-type: none"> <li>- Bigger radius</li> </ul>	<ul style="list-style-type: none"> <li>- Use "method of altering feed rate"</li> </ul>
Crater wear/breakage due to crater wear	<ul style="list-style-type: none"> <li>- Sharper cutting edge for reduced cutting force</li> </ul>	<ul style="list-style-type: none"> <li>- Reduce cutting speed</li> <li>- Increase feed rate to minimise operation time and to increase distance between cutting edge and crater</li> </ul>
Chipping due to rough condition or vibration	<ul style="list-style-type: none"> <li>- Bigger negative chamfer angle and/or honed chamfer</li> </ul>	<ul style="list-style-type: none"> <li>- Increase feed rate to reduce number of hits</li> </ul>
Flaking	<ul style="list-style-type: none"> <li>- Sharper cutting edge to reduce cutting force</li> <li>- Smaller negative chamfer</li> <li>- Use positive inserts</li> </ul>	<ul style="list-style-type: none"> <li>- Increase feed rate to reduce operation time</li> </ul>
Thermal crack/breakage	<ul style="list-style-type: none"> <li>- Sharper cutting edge for reduced cutting force</li> <li>- Smaller negative chamfer</li> <li>- Use positive inserts</li> </ul>	<ul style="list-style-type: none"> <li>- Reduce cutting speed, feed rate and depth of cut</li> <li>- Dry machining</li> </ul>
Chipping	<ul style="list-style-type: none"> <li>- Bigger negative chamfer</li> </ul>	<ul style="list-style-type: none"> <li>- Increase cutting speed to reduce cutting force</li> </ul>

For investigation please send us the used inserts. If breakage is the problem please use inserts only 80–90% of expected tool life because broken inserts almost have no information.

**A**

Turning

**B**

Milling

**C**

Drilling

**D**

Technical Information

**E**

Index

### Trouble shooting – threading

Problème	Cause	Solution
Big flank wear	– Cutting speed too high	– Reduce cutting speed
	– Width of cut too small	– Reduce number of width of cut
	– Insert over/under centre line	– Adjust insert height
Asymmetric wear on left and right cutting edge	– Width of cut not optimal	– Adjust width of cut
	– Inclination angle and lead angle are not optimally aligned	– Change the shim to get the correct angle
Breakage	– Cutting speed too low	– Increase cutting speed
	– Cutting force too high	– Increase number of width of cut – Reduce width of cut
	– Unstable conditions	– Improve clamping and overhang to avoid vibrations
	– Bad chip control	– Increase coolant pressure for better chip removal
Déformation plastique	– Cutting speed and temperature too high	– Reduce cutting speed – Increase number of width of cut – Reduce width of cut
	– Insufficient coolant supply	– Improve coolant supply
Mauvais état de surface du filet	– Cutting speed too low	– Increase cutting speed
	– Insert over/under centre line	– Adjust insert height
	– Bad chip control	– Change feed rate and/or width of cut
Profil de filet incorrect	– Incorrect insert height	– Change insert height
	– Tool holder doesn't form a 90° angle	– Adjust tool holder
	– Pitch error in machine	– Adjust machine
Profil de filetage de profondeur insuffisante	– Incorrect insert height	– Change insert height
	– Breakage of cutting edge	– Change insert
	– Excessive wear	– Change insert
Formation d'arêtes rapportées	– Temperature on cutting edge is too low	– Increase cutting speed
	– Often occurs when machining of carbon steel and stainless steel	– Use grade with sufficient toughness (PVD coated)
Vibrations	– Incorrect cutting data	– Increase or highly decrease cutting speed
	– Incorrect insert height	– Change insert height
	– Insufficient clamping	– Improve clamping system and minimise overhang

A

Turning

B

Milling

C

Drilling

D

Technical Information

E

Index

## General turning

### Cutting tool geometry

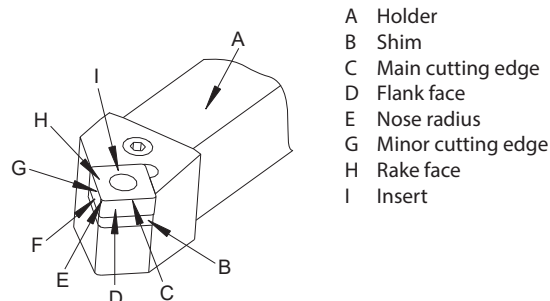
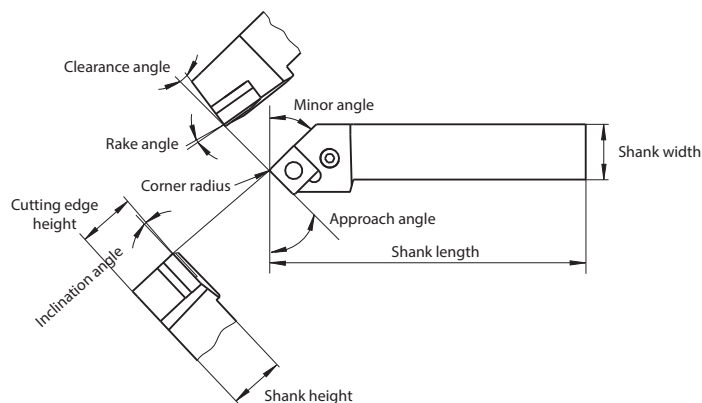

- A Holder
- B Shim
- C Main cutting edge
- D Flank face
- E Nose radius
- G Minor cutting edge
- H Rake face
- I Insert

### Rake angle

The rake angle is a cutting edge angle that has large effects on cutting resistance, chip disposal, cutting temperature and tool life. Increasing the rake angle in positive direction improves the sharpness of the cutting edge and the cutting force decreases but at the same time it lowers the strength. To increase the cutting resistance the rake angle must be increased in negative direction.

Rake angle	Applications
Small	Machining of fragile and hard materials, roughing and interrupted cut
Large	Machining of plastic materials and soft materials, precision machining

### Clearance angle

The flank angle prevents friction between the flank face and work piece resulting in smooth feed. Increasing the flank angle decreases the cutting force and the surface roughness becomes better but on the other hand this lowers the cutting edge strength and decreases the flank wear occurrence.

Clearance angle	Applications
Small	Machining of hard and demure materials, for roughing operation with stable cutting edge
Large	Precision machining with low cutting force, work pieces suffer from work hardening easily

### Inclination angle

The positive and negative edge inclination angle determines the discharging direction of chips. In heavy cutting, the cutting edge receives extremely large shocks at the beginning of cutting. Cutting edge inclination keeps the cutting edge from receiving this shock and prevents fracturing. On the other hand the back force increases and occurs vibration. For a finishing operation a positive angle is more suitable.

When the edge inclination angle is negative, i.e. the cutting edge is located at the lowest point relative to the bottom plane of the tool holder, the chips flow to the machined surface of workpiece.

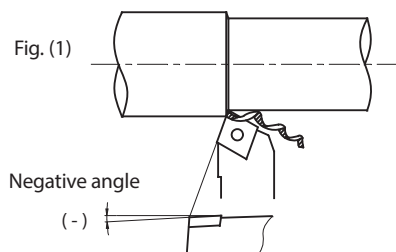

As shown in Fig. (2), when the edge inclination angle is positive, i.e. the cutting edge is located at the highest point relative to the bottom plane of the tool holder, the chips flow to the un-machined surface of workpiece.

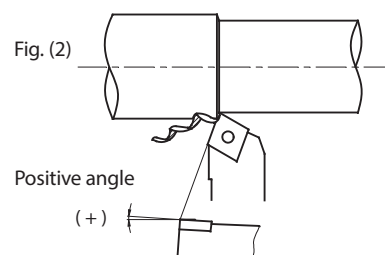

A

Turning

B

Milling

C

Drilling

D

Technical Information

E

Index



## A

### Turning

### General turning

#### Entering angle (main cutting edge)

Reducing the lead angle increases the strength of the cutting edge. Because the lead angle is small, the cutting width is long, the force on the unit cutting edge length is small. At the same time, reducing the lead angle can increase the tool life. Normally, when turning thin long shaft and ladder shaft, the lead angle adapts 90°. The lead angle is increased, radial force is reduced, cutting is stable, cutting thickness is increased and chip breaking performance is good.

Entering angle	Applications
Small	For material with high tensile strength, high hardness or hardened layer on surface
Large	For machining with low rigidity

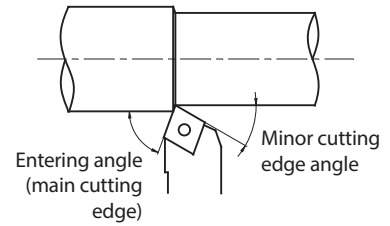

## B

### Milling

#### Minor cutting edge

The minor cutting edge angle is the main angle on influence surface roughness; its size is also influence strength of cutter. When the minor cutting edge angle is too small, the cutting force increases and results in chattering and vibration. The selection principle for the minor cutting edge angle is under the condition of rough machining, or un-influencing friction and producing vibration, the smaller angle should be chosen; the bigger angle can be used for precision machining.

#### Nose radius

The nose radius effects the cutting edge strength and the finished surface. By increasing the nose radius the surface finish becomes better and the cutting edge strength improves. Flank and rake wear decreases. If the radius becomes too big, the cutting force increases and causes vibration which effects the chip control negative.

Radius	Applications
Small	Finishing with small cutting depth, machining thin long shaft, rigidity of machine is insufficient
Large	Rough machining, high cutting edge strength is required, rigidity of machine is good, machining hardened materials and interrupted cut

## C

### Drilling

## D

### Technical Information

## E

### Index

General turning

Cutting speed  $V_c$

$$V_c = \frac{\pi \times D \times n}{1000} \text{ [m/min]}$$

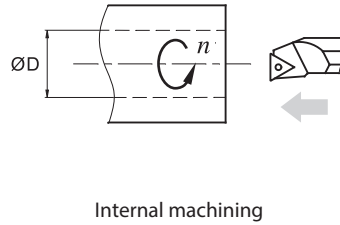
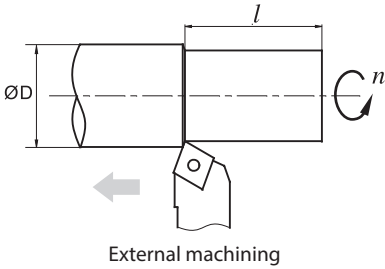

$V_c$ : Cutting speed [m/min]  
 $n$ : Revolution [1/min]  
 $f$ : Feed rate [mm]

Example:  $n = 250$  1/min,  $f = 0,2$  mm,  
 $l = 150$  mm  
 Result: [insert values in formula  $V_c$ ]

Feed rate  $F$

$$f = \frac{l}{n} \text{ [mm/rev]}$$

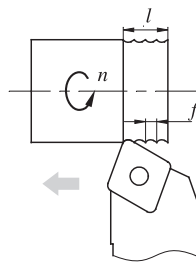

$f$ : Feed rate [mm]  
 $l$ : Cutting length [mm/min]  
 $n$ : Revolution [1/min]

Example:  $n = 500$  1/min,  $l = 100$  mm/min  
 Result: [insert values in formula  $f$ ]

$$f = \frac{l}{n} = \frac{100}{500} = 0,2 \text{ mm}$$

Cutting time  $T_c$

$$T_c = \frac{l}{f \times n} \text{ [min]}$$

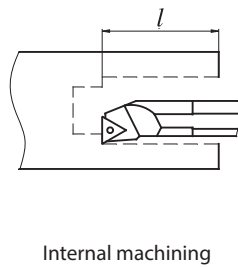
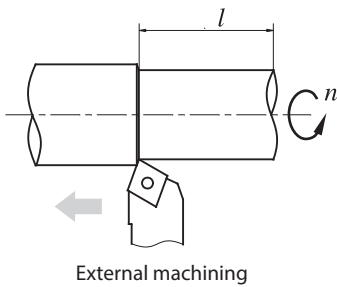

$T_c$ : Cutting time [min]  
 $l$ : Cutting length [mm/min]  
 $f$ : Feed rate [mm]  
 $n$ : Revolution [1/min]

Example:  $n = 250$  1/min,  $f = 0,2$  mm,  
 $l = 150$  mm  
 Result: [insert values in formula  $T_c$ ]

A

Turning

B

Milling

C

Drilling

D

Technical Information

E

Index

A

## General turning

Cutting time  $T_C$  for face milling

$$T_C = \frac{\pi \times (a^2 - b^2)}{4000 \times V_C \times f} \text{ [min]}$$

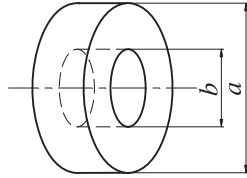

$T_C$ : Cutting time [min]  
 $V_C$ : Cutting speed [m/min]  
 $f$ : Feed rate [mm]

Turning

B

Theoretical surface roughness R

$$R = \frac{f^2}{8r_c} \times 1000 \text{ [\mu m]}$$

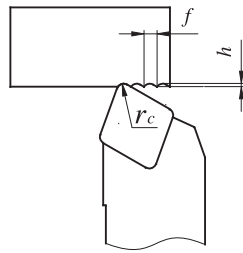

R: Surface roughness [ $\mu\text{m}$ ]  
f: Feed rate [mm]  
 $r_c$ : Radius of insert [mm]

Example:  $f = 0,2 \text{ mm}$ ,  
 $r_c = 0,4 \text{ mm}$

Milling

C

Drilling

D

Technical Information

E

Index

## General turning

### Three effects of cutting condition for turning

Today short machining time, long tool life and high machining accuracy is expected from modern tools. Based on the machine performance, material shape and hardness of the components the right choice of tool and cutting conditions are the premise for a successful machining process. Cutting speed, feed rate and depth of cut are what we call the "Three effects of cutting".

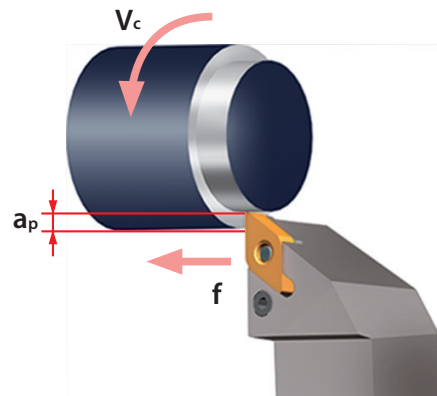

#### 1. Cutting speed ( $V_c$ )

Cutting speed is defined as the rate (or speed) that the material moves past the cutting edge of the tool. The unit for  $V_c$  is meter per minute [m/min].

**Cutting speed influence:** Cutting speed is one of the three important effects of turning and has influence on tool life. Increasing the cutting speed also increases the cutting temperature and that decreases the tool life. Depending on the hardness and type of material the cutting speed varies. Therefore to choose a suitable grade for the cutting speed is necessary.

In general situation, when cutting speed is increased by 20% the tool life will be reduced  $\frac{1}{2}$ ; when the cutting speed is increased by 50% the tool life decreases  $\frac{1}{3}$ . Lower cutting speed results in vibration which will shorten tool life.

#### 2. Feed rate ( $f$ )

In turning application feed rate is the distance the tool holder moves per work piece revolution. That has influence to the surface quality. The unit for feed rate is millimetre per revolution [mm/rev]

**Feed rate influence:** Decreasing the feed rate will increase flank wear and tool life will be shortened. Increasing the feed rate increases the cutting temperature and also flank wear. On the other hand the efficiency will be improved.

#### 3. Depth of cut ( $a_p$ )

The depth of cut refers to the half different value between the diameter of the unmachined and machined work piece. The unit is millimetre [mm].

**Depth of cut influence:** Changing depth of cut has no big influence to the tool life. Machining hardened layer with small depth of cut results in friction and short tool life. Machining uncut surface or cast iron material, choose maximum depth of cut according to the machine power so that the cutting edge and corner radius is out of the hardened layer. That helps to prevent chipping and abnormal wear.

A

Turning

B

Milling

C

Drilling

D

Technical  
Information

E

Index

A

## Parting & grooving

### Adjusting the cutting edge height

- Mount the tool holder in a 90° angle to the central axis of the workpiece. This improves the surface quality and decreases the risk of vibrations.

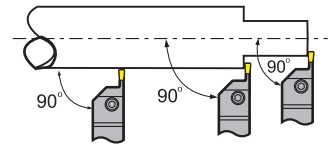

- Height tolerance between the cutting edge of the insert and the centre of the work piece should be kept  $\pm 0.1$  mm, especially for parting of rods and grooving of materials with a small diameter. This extends the tool life and reduces the cutting forces as well as the formation of burrs.

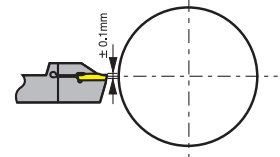

Turning

B

### Parting off

- When the cutting edge nears the central axis of the work piece, reducing the feed rate by 30 % can extend the tool life of the insert.
- Pick a tool holder with the smallest possible overhang to avoid vibrations and tool deflection.

Milling

C

### Longitudinal turning and profile turning

- Machining sequence 0.5 mm:
  1. Bring radial feed rate to required cutting depth (ap max.  $0.75 \times$  cutting edge width)
  2. Radial relocating by 0.1 mm
  3. Longitudinal turning to opposite shoulder
  4. Diagonal relocating by 0.5 mm outward axial feed rate to the starting point
  5. Radial feed rate to required cutting depth, etc.

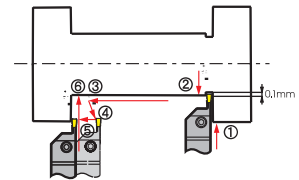

- When machining the chamfer or the base of the slot follow the steps as shown in figure. This reduces tool deflection and avoids cutting edge chipping.

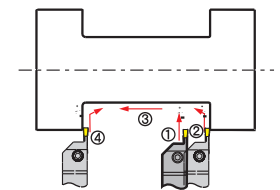

Drilling

D

### Surface grooving and turning

- Roughing: Processing from largest diameter to the axis. When returning it's recommended to bend the tool slightly.

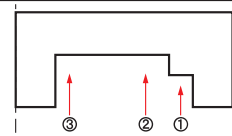

- Flute turning: Depth of axial turning less than  $0.75 \times S$  (width of insert). When the pocket width is bigger than the depth follow the working steps as shown. When the pocket depth is bigger than the width, we recommend to go to the required diameter step by step.

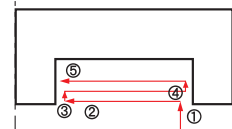

- Finishing: When finishing begin with the outer diameter and the bottom. Then go on with the inner diameter to the required size.

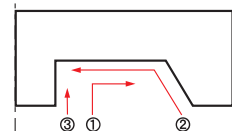

Technical Information

E

### Internal machining

- Procedure according to figure. For better chip removal in blind holes machine from the inside out.

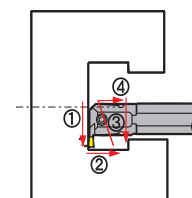

Index

## Threading

### Steps for best results when thread-cutting

1. Choice of threading method
2. Choice of angle and shim
3. Choice of tool holder and inserts
4. Choice of cutting data
5. Choice of cutting direction

### Thread turning method

#### External machining

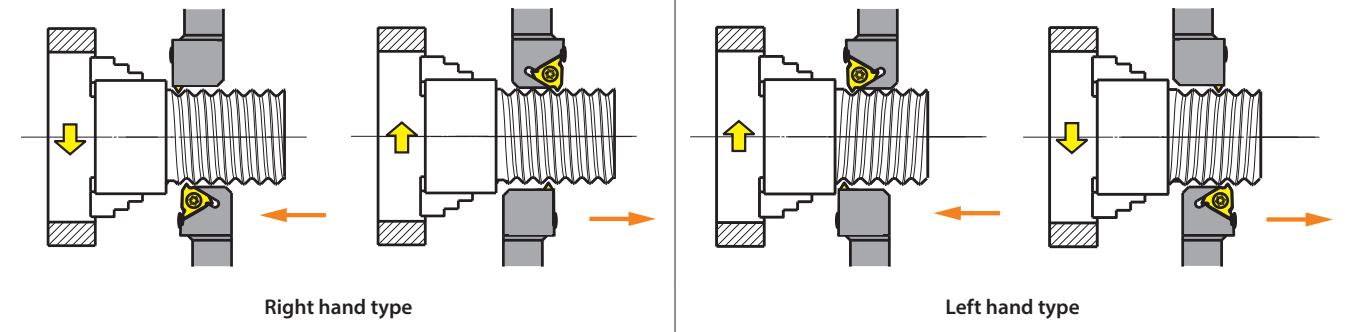

#### Internal machining

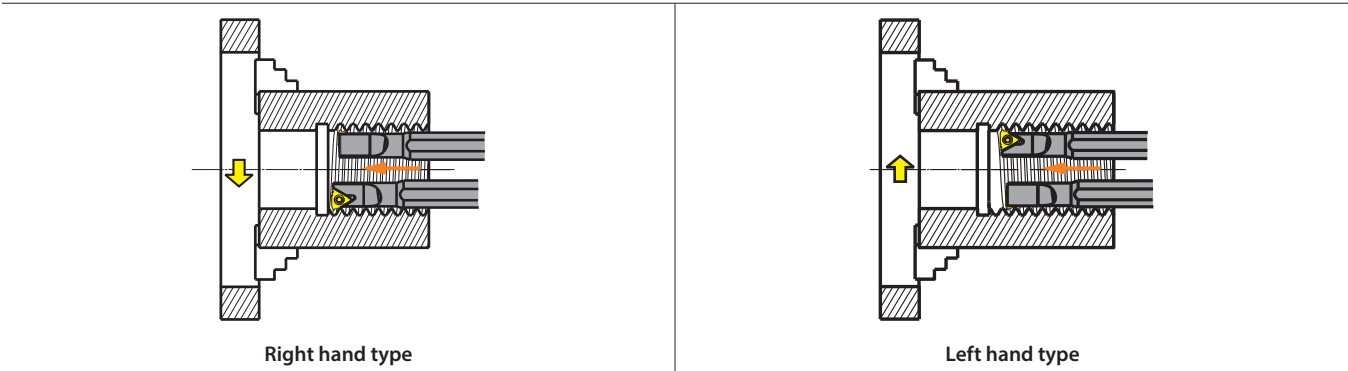

A

Turning

B

Milling

C

Drilling

D

Technical  
Information

E

Index

## Choice of angle and shim

### Choice of angle

The flank clearance angles of the thread profile depend on the helical angle of the thread. The helical angle of the thread must coincide with the insert's angle of inclination angle as far as possible to get the ideal profile, to avoid longer unfavourable wear on one of the flanks and thus to ensure tool life.

$$\lambda = \arctan \frac{p}{d_2 \times \pi}$$

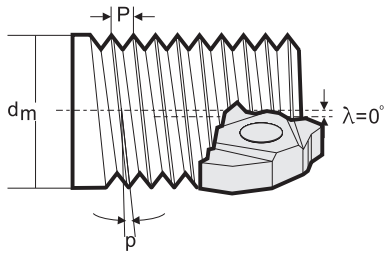

Helix angle (p)

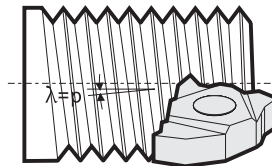

Pitch angle (λ)

p Pitch  
d<sub>2</sub> Flank diameter  
λ Pitch angle

### Choice of shim

Pitch range	Dimension	Pitch angle	Shim
0,5–0,3	16	0	MT16-00M
		1	MT16-01M
		2	MT16-02M
		3	MT16-03M
3,5–6,0	22	0	MT22-00M
		1	MT22-01M
		2	MT22-02M
		3	MT22-03M

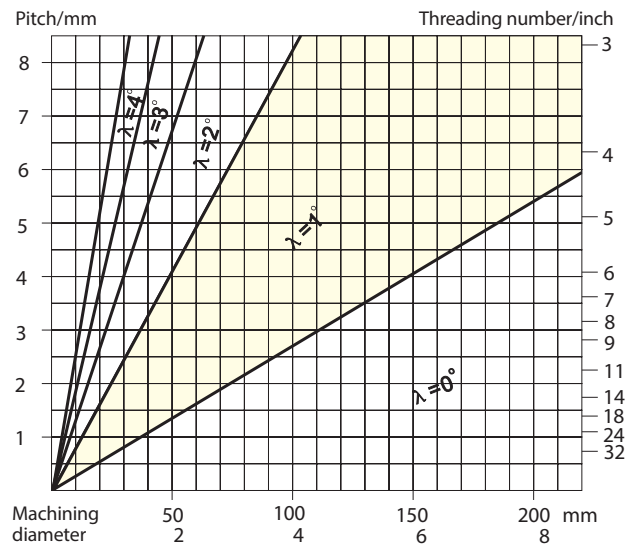

The shim  $\lambda = 1^\circ$  is delivered with the tool holder.

### Infeed way of threading

The number of passes and widths of cut are the key points of threading operation. Please choose the cutting parameters with the recommended form according to experience data. In case of breakages or too much wear please have a look at page A447 (trouble shooting).

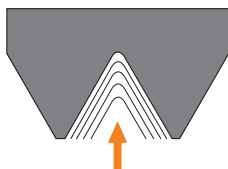

Radial width of cut

Radial width of cut requires low cutting depth, sharp cutting edge and tough grade. It is recommended when the pitch is smaller than 2 mm, not ideal for material with long chips.

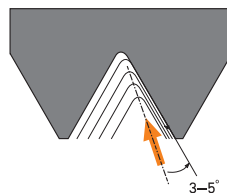

Modified flank width of cut

Infeed at an angle of 3–5° to the flank of the teeth. It is easy for chips flow. Suitable for long chip material and internal threading.

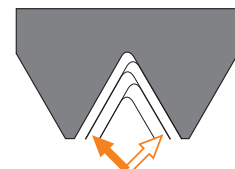

Alternating width of cut

Alternating width of cut is mainly used for large pitches and long chip materials. To get equal insert wear on both edges.

# Go directly to the special tool tailored for your turning applications

Are there turning applications at your company where having custom tools tailored to your unique needs would deliver real benefits both in terms of logistics and at a technical and commercial level? ZCC Cutting Tools Europe is there to advise and assist you during the planning, development and ordering process. Use our new online tool to request a special tool and get your personal quotation in just a few short steps (<https://www.zcct-europe.com/en/tools/special-tools/>).

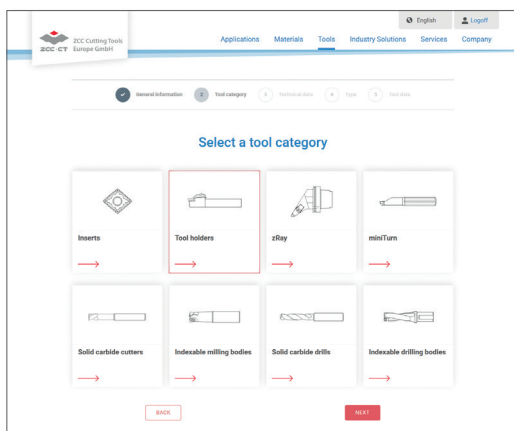

'Online tool for special tools' launch page where you can select the tool category

## Selecting the tool category

Scan the QR code on this page to go directly to the launch page of our online tool where you can request the special tool you need. You can begin by selecting the tool category you need. It's that easy.

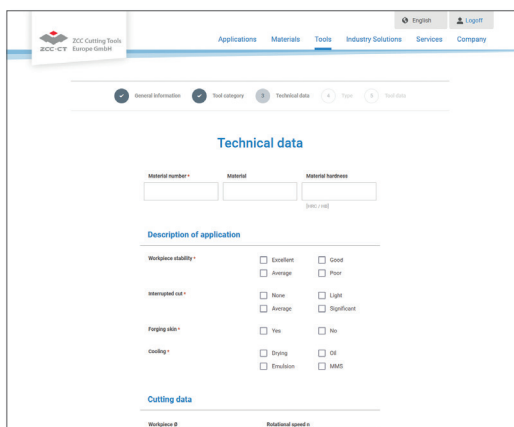

Define the relevant tool parameters.

## Defining the tool parameters

You are now guided step by step through the process. You can also securely upload your drawings, diagrams and 3D models (where available).

It's the easy way to order your custom-made special tool from ZCC Cutting Tools Europe GmbH.



Now go directly to the new **special tool form** on our website and get started.