

# PARTING & GROOVING

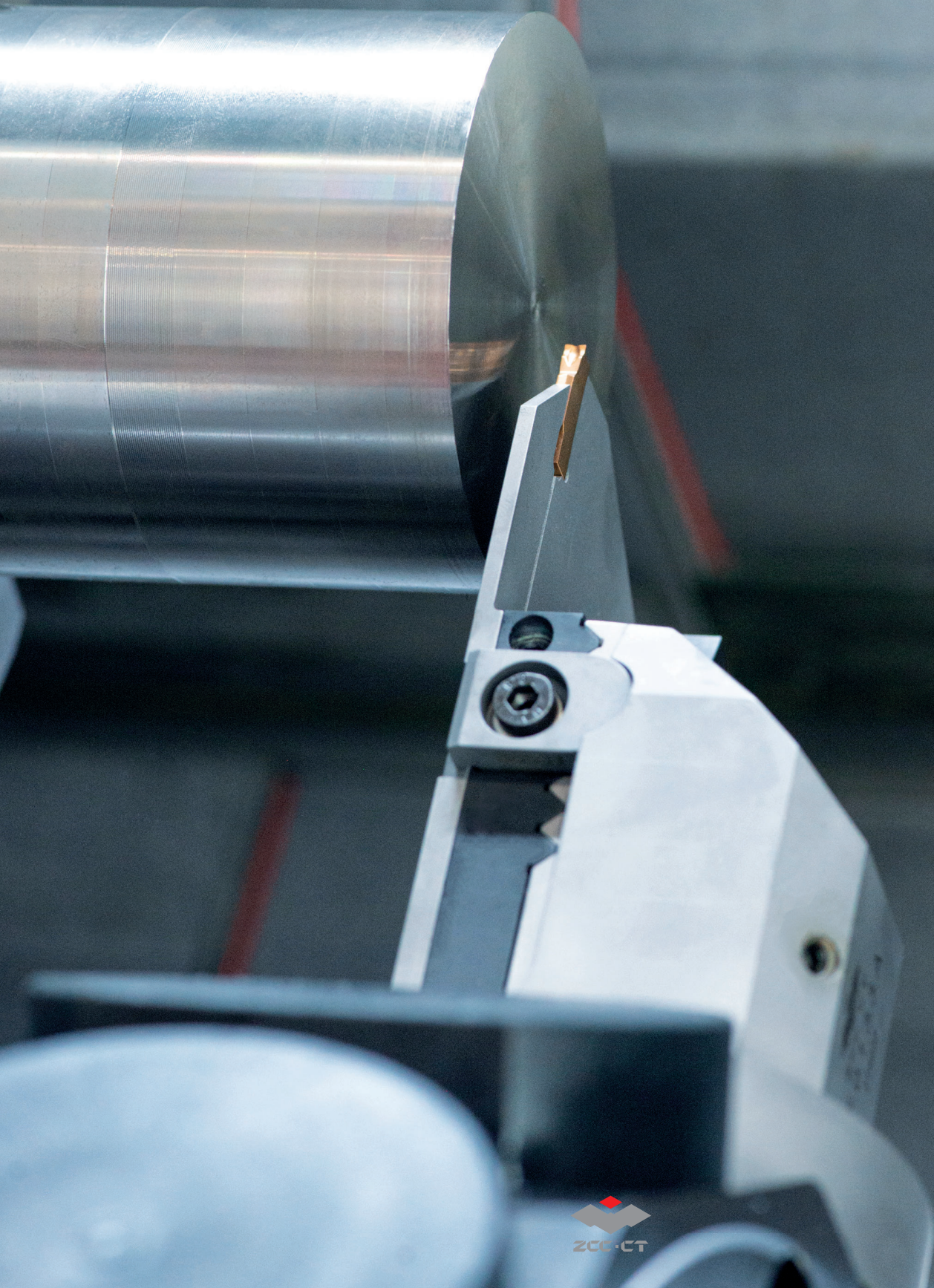

**A**

Turning

**B**

Milling

**C**

Drilling

**D**Technical  
Information**E**

Index



## Parting & grooving

Product overview	A382-A383
System overview	A384-A385
Tool holder orientation	A386-A387
Chip breaker overview	A388-A389
Application fields of chip breakers	A390-A391
Grade overview	A392-A393
Application fields of grades	A394-A397
System code – inserts	A398
Inserts	A399-A415
System code – inserts – QC series	A416
Inserts – QC series	A417-A421
System code – tool holders	A422-A424
Tool holders	A425-A445
Precision monoblock tool holder	A446-A451
System code – tool holders – QC series	A452
Tool holders – QC series	A453-A455
Recommended cutting data	A456-A457
Technical Information	A510
Special tools	A513

## Parting & grooving inserts

### Double sided



**ZT\*D-MM**

2-8

A399



**ZT\*D-MG**

2.5-6

A404



**ZT\*\*-EG**

1-6.5

A407



**ZP\*D-MG**

2.5-6

A400



**ZP\*D-MG-R/L**

2.35-2.85

A401

Width

Page



**ZR\*D-MG**

2.5-6

A410



**ZR\*D-EG**

3-6

A411



**ZR\*D-LH**

6-8

A414



**ZILD-LC**

8

A415

Width

Page

### Single sided



**ZT\*S-MM**

2.5-6

A406



**ZT\*S-MG**

5-6

A405



**ZP\*S-MG**

2.5-6

A402

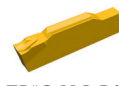

**ZP\*S-MG-R/L**

2.5-3

A403



**ZIMF-NM**

3-6

A412



**ZIGQ-NM**

3-6

A413

Width

Page

### Three cutting edges



**QC\*\*R/L**

0.75-4.8

A417



**QC\*\*R/L\*\*\*R**

1-4

A420

Width

Page

A

Turning

B

Milling

C

Drilling

















D

Technical Information

E

Index

## External tool holders

							
<b>GQC**R/L</b>	<b>QE**R/L</b>	<b>QE*S**N</b>	<b>QE*S**N-1</b>	<b>QE*SN30</b>	<b>QE*SR/L</b>	<b>QECDR/L</b>	
A453	A425	A431	A432	A427	A430	A428	Page
							
<b>QF**R/L</b>	<b>QF**RR/LL</b>	<b>QF*DR/L</b>	<b>QF*SRR/LL</b>	<b>QFHSDR/L</b>	<b>QX*DR/L</b>	<b>QZS*</b>	
A434	A436	A439	A438	A441	A429	A433	Page
							
<b>QE**R/L-DGC</b>	<b>QE**R/L-DGSC</b>	<b>QE**R/L-SC</b>					
A446	A448	A449					Page

## Boring bars

			
<b>C***-Q*DR/L</b>	<b>C40X-Q*DR/L</b>	<b>S*K-QC**R/L</b>	
A444	A443	A454	Page

A

Turning

B

Milling

C

Drilling

D

Technical  
Information

E

Index

	System information	Groove width S	Groove depth a, max.	Grooving	Parting	Turning	Page
<p><b>A</b></p> <p>Turning</p>	<p><b>QE system</b></p> <ul style="list-style-type: none"> <li>System for <b>radial parting off and grooving</b> and <b>turning</b></li> <li>Tool holders available for internal and external machining</li> <li>Available with targeted cooling and direct supply of coolant via the shank</li> <li>Inserts with one or two cutting edges</li> <li>Inserts for precision grooving available</li> </ul>	2,0–6,0 mm	max 30,0 mm	✓	✓	✓	<ul style="list-style-type: none"> <li>■ A425</li> <li>● A444</li> </ul>
<p><b>B</b></p> <p>Milling</p>	<p><b>QZ and QE system</b></p> <ul style="list-style-type: none"> <li>System for <b>radial parting off and grooving</b></li> <li>Insert holder and clamping block in one</li> <li>Self-clamping system</li> <li>Inserts with one cutting edge</li> <li>Can be used in a wide range of applications</li> </ul>	2,5–6,0 mm	max 60,0 mm	✓	✓	–	■ A431
<p><b>C</b></p> <p>Drilling</p>	<p><b>QF system</b></p> <ul style="list-style-type: none"> <li>System for radial <b>grooving and turning</b></li> <li>Penetration diameter range of Ø 48–400 mm</li> <li>Screw clamped for maximum stability</li> <li>Inserts with two cutting edges</li> <li>Tool holders available in a neutral design or with a 90° offset</li> <li>Right base for M3</li> <li>Left base for M4</li> </ul>	2,0–6,0 mm	max 22,0 mm	✓	–	✓	■ A434
<p><b>D</b></p> <p>Technical Information</p>	<p><b>QX system</b></p> <ul style="list-style-type: none"> <li>System for <b>undercutting</b></li> <li>Shank holder with 45° approach angle</li> <li>Screw clamped for maximum stability</li> <li>For grooving inserts with two cutting edges</li> <li>For turning operations and machining undercuts and recesses. Can also be used in copy turning applications</li> </ul>	3,0–6,0 mm	max 4,0 mm	✓	–	✓	■ A429

■ External tool holders  
● Boring bars

	System information	Groove width S	Groove depth a, max.	Grooving	Parting	Turning	Page
<b>C*X-Q system</b>	<ul style="list-style-type: none"> <li>Special system for <b>machining aluminium wheels</b></li> <li>Boring bar with 15° approach angle</li> <li>Screw clamped for maximum stability</li> <li>For grooving inserts with two cutting edges</li> <li>Penetration diameter range from Ø 160 mm</li> <li>Special chip breakers for aluminium machining</li> </ul>	6,0–8,0 mm	max 80,0 mm	–	–	✓	● A443
<b>QE*S*N system</b>	<ul style="list-style-type: none"> <li>System specially designed for <b>heat-resistant alloys</b></li> <li>Special chip breakers for heat-resistant alloys</li> <li>Screw clamped for maximum stability</li> <li>For grooving inserts with one cutting edge</li> </ul>	3,0–6,0 mm	max 22,0 mm	✓	–	✓	■ A430
<b>QC system</b>	<ul style="list-style-type: none"> <li>System for <b>precision grooving</b></li> <li>Tool holders available for external and internal machining</li> <li>Tangential screw clamping for high stability and rigidity</li> <li>Three cutting edges for high efficiency</li> <li>Precision-ground grooving inserts with high tolerances</li> <li>High repeatability even after replacing insert</li> <li>Grooving inserts with straight or round cutting edge</li> <li>Special feature with internal machining: right tool holder + left grooving insert / left tool holder + right grooving insert</li> </ul>	0,5–4,8 mm	max 5,0 mm	✓	–	–	■ A453 ● A454

■ External tool holders  
● Boring bars

A

Turning

B

Milling

C

Drilling

D

Technical Information

E

Index

## Tool holders for axial machining

Tool holder	Tool holder orientation
<p><b>A</b></p> <p>Turning</p> <p>QFFD****L**_**H</p>	 <p>CW/M3</p>
<p><b>B</b></p> <p>Milling</p> <p>QFFD****R**_**H</p>	 <p>CCW/M4</p>
<p><b>C</b></p> <p>Drilling</p> <p>QFFD****LL**_**H</p>	 <p>CCW/M4</p>
<p><b>D</b></p> <p>Technical Information</p> <p>QFFD****L**_**L</p>	 <p>CCW/M4</p>
<p><b>E</b></p> <p>Index</p> <p>QFFD****R**_**L</p>	 <p>CW/M3</p>





**A**

## Grooving

MM P M K S



Turning

Sintered chip breaker with straight cutting edge for general machining of steel, stainless steel, cast iron and difficult-to-machine materials. Can be used for grooving, turning and parting off.

**B**

MG P M K S

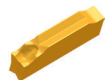

Milling

Sintered chip breaker for general machining of steel, stainless steel, cast iron and difficult-to-machine materials. Can be used for grooving, turning and parting off.

**C**

MG P M K S



Drilling

Universal chip breaker with round profile for general machining of steel, stainless steel and cast iron. Suitable for grooving and profiling.

**D**

EG M P S



Technical Information

Ground precision chip breaker for grooving and turning applications. Suitable for machining of stainless steel. E-tolerance for high repeatability.

EG M P S



Ground precision chip breaker with round profile for grooving and turning applications. Suitable for machining of stainless steel. E-tolerance for high repeatability.

**E**

NM S

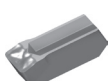

Index

Special chip breaker for machining of heat-resistant materials.

## Grooving

**LC** **N**



Ground chip breaker for profile and turning applications of non-ferrous metals.

**LH** **N**



Ground chip breaker for profile and turning applications of non-ferrous metals.

**A**

Turning

**B**

Milling

**C**

Drilling

**D**

Technical  
Information

**E**

Index

# Parting & grooving Application fields of chip breakers

**A**  
 Turning  
**B**  
 Milling  
**C**  
 Drilling  
**D**  
 Technical Information  
**E**  
 Index

Chip breaker	Application	P	M	K	N	S	H	Feed	Cutting edge design
ZT****-MM	Parting & grooving ✓								
	Turning ✓	✓	✓	✓		✓			
ZP****-MG	Parting & grooving ✓								
	Turning -	✓	✓	✓		✓			
ZT****-MG	Parting & grooving ✓								
	Turning ✓	✓	✓	✓		✓			
ZR****-MG	Parting & grooving ✓								
	Turning ✓	✓	✓	✓		✓			
ZT****-EG	Parting & grooving ✓								
	Turning ✓	✓	✓	✓		✓			
ZR****-EG	Parting & grooving ✓								
	Turning ✓	✓	✓	✓		✓			
ZI****-NM	Parting & grooving ✓								
	Turning ✓		✓		✓	✓			

✓ Very suitable    ✓ Suitable

■ Parting & grooving  
■ Turning

Chip breaker	Application	P	M	K	N	S	H	Feed	Cutting edge design
ZR****-LH	Parting & grooving ✓				✓	✓			Round profile 
	Turning ✓								
ZI****-LC	Parting & grooving ✓				✓	✓			Round profile 
	Turning ✓								

✓ Very suitable

✓ Suitable

■ Parting & grooving

■ Turning

<b>A</b>	Turning
<b>B</b>	Milling
<b>C</b>	Drilling
<b>D</b>	Technical Information
<b>E</b>	Index

**A**  
Turning

**B**  
Milling

**C**  
Drilling

**D**  
Technical Information

**E**  
Index

## Parting & grooving

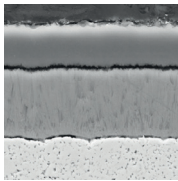
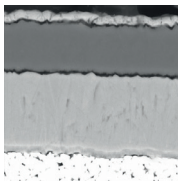
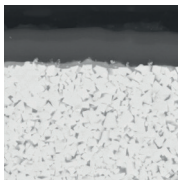
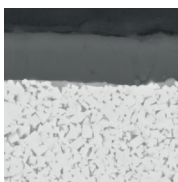
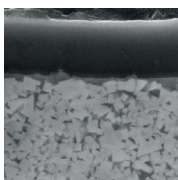
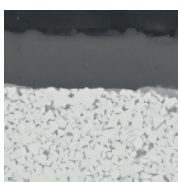
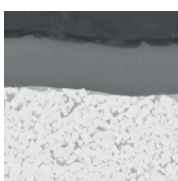
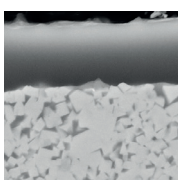
Grade	ISO	Micro structure	Grade description
<b>YBC252</b>	P20 - P35		CVD coated P20–P35 carbide grade for medium operation to roughing of steel and casting steel. Optimal performance of wear resistance and toughness for a wide application field.
<b>YBC251</b>	P20 - P35		CVD coated P20–P35 carbide grade for medium operation to roughing of steel and casting steel in lower cutting speed.
<b>YBG105</b>	S05 - S20		PVD multilayer coated S05–S20 carbide substrate for finishing to medium application of super alloy material but also stainless steel. Good wear resistance and thermal stability in a wide application field.
<b>YBG102</b>	S05 - S15		PVD coated S05–S15 carbide substrate for finishing to medium application of super alloy material, stainless steel and aluminum. Good wear resistance in a wide application field.
<b>YB9320</b>	P10 - P30 M10 - M25		PVD multilayer coated P10–P30/M10–M25 carbide substrate for finishing to medium machining of stainless steel, super alloys and steel (grooving/milling). Optimised coating stability for higher wear resistance and thermal stability in a wide range of applications.
<b>YBG205</b>	P10 - P30 M20 - M40 S15-S25		PVD multilayer coated P10–P30/M20–M40/S15–S25 carbide substrate for finishing to medium machining of stainless steel, super alloys and steel (milling). Excellent wear resistance and thermal stability in a wide range of applications.
<b>YBG202</b>	P10 - P30 M10 - M25		PVD coated P10–P30/M10–M25 carbide substrate for finishing to medium application of stainless steel and steel (milling). Good wear resistance in a wide application field.
<b>YBG302</b>	P15 - P30 M25 - M40		PVD coated P15–P30/M25–M40 carbide substrate for medium roughing application of stainless steel and steel (milling). Good wear resistance and toughness.

**Parting & grooving**

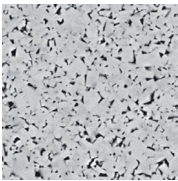
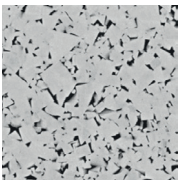
Grade	ISO	Micro structure	Grade description
<b>YD101</b>	K05 - K20 N05 - N20		Uncoated K05–K20/N05–N20 carbide substrate for fine to medium application in aluminum and other material.
<b>YD201</b>	K10 - K30 N10 - N30		Uncoated K10–K30/N10–N30 carbide substrate for medium application in aluminum and other material.

**A**

Turning

**B**

Milling

**C**

Drilling

**D**Technical  
Information**E**

Index

## CVD coated carbide grades for steel

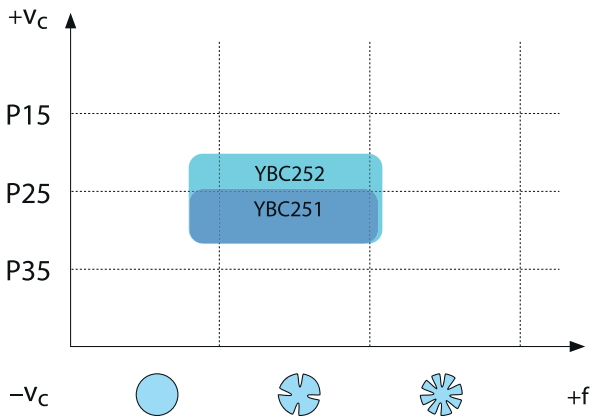

## PVD coated carbide grades for stainless steel

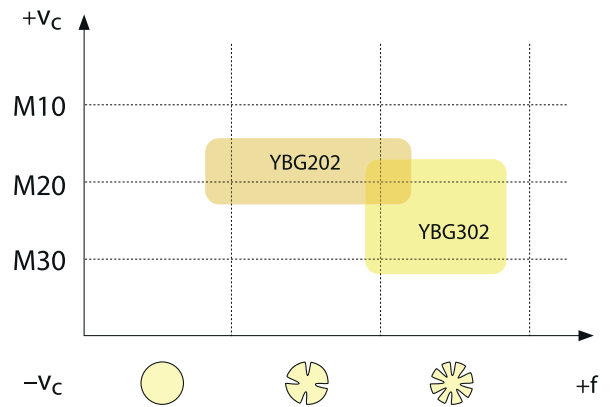
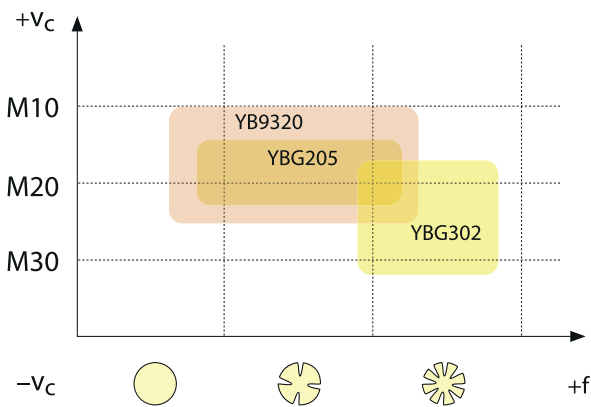

## PVD coated carbide grades for superalloys

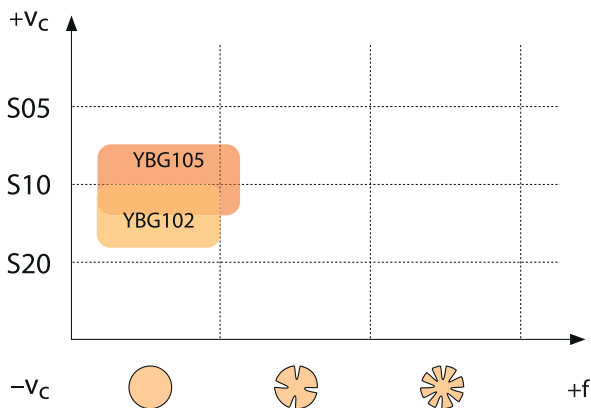

A

Turning

B

Milling

C

Drilling

D

Technical Information

E

Index

**Carbide grades for non-ferrous metals**

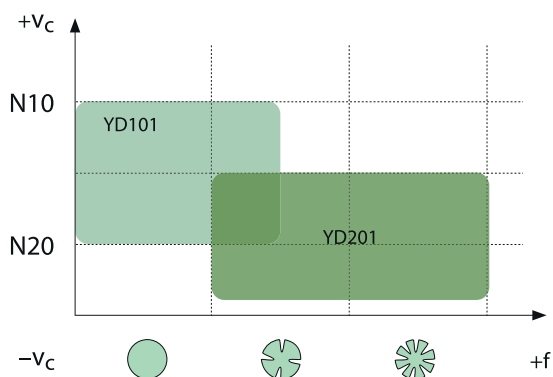

**A**

Turning

**B**

Milling

**C**

Drilling

**D**

Technical  
Information

**E**

Index



## Application fields of grades – parting & grooving

	ISO	HC <sup>1</sup> (CVD)	HC <sup>1</sup> (PVD)	HT	HC <sup>2</sup>	Ceramic	HW	CBN	PCD
<b>A</b> Turning	P01								
	P10								
	P20	YBC251 YBC252							
	P30								
	P40								
<b>B</b> Milling	M01								
	M10								
	M20		YBG202 YBG205 YB9320 YBG302						
	M30								
	M40								
<b>C</b> Drilling	K01								
	K10								
	K20								
	K30								
<b>D</b> Technical Information	N01						YD101 YD102		
	N10								
	N20								
	N30								
<b>E</b> Index	S01								
	S10		YBG102 YBG105						
	S20								
	S30								
<b>F</b> Index	H01								
	H10								
	H20								
	H30								

<b>P</b>	Steel
<b>M</b>	Stainless steel
<b>K</b>	Cast iron

<b>N</b>	Non-ferrous metals
<b>S</b>	Heat-resistant alloys
<b>H</b>	Hardened materials

HC <sup>1</sup>	Coated carbide
HT	Uncoated cermet
HC <sup>2</sup>	Coated cermet
HW	Uncoated carbide



## ZP G D 04 04 – M G

1 2 3 4 5 6 7

A

Turning

B

Milling

C

Drilling

D

Technical Information

E

Index

Application	
Code	Description
ZP	Parting
ZT	Grooving & turning
ZR	Form turning

1

Insert seat size [mm]	
Groove width	
Code	Description
B	2,0
E	2,5
F	3,0
G	4,0
H	5,0
K	6,0
L	8,0

2

No. of cutting edges	
Code	Description
S	Single
D	Double

3

Insert thickness S [mm]	
	
Code	S
02	2,0
025	2,5
03	3,0
04	4,0
05	5,0
06	6,0
08	8,0

4

Nose radius r [mm]	
	
Code	r
02	0,2
03	0,3
04	0,4
08	0,8



5

Tolerance class [mm]	
Code	Description
M	±0,13
E	±0,025











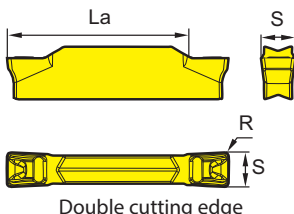







6

Chip breaker	
Code	Description
G	General chip breaker
F	Special chip breaker
M	Straight edge

7

-  Ideal machining conditions
-  Normal machining conditions
-  Unfavourable machining conditions

Parting inserts

ZT** parting & grooving insert (double sided)						HC <sup>1</sup> (CVD)		HC <sup>1</sup> (PVD)				HW	
 <p>Double cutting edge</p>	<b>P</b>												
	<b>M</b>												
	<b>K</b>												
	<b>N</b>												
	<b>S</b>												
	<b>H</b>												
ISO	R±0.1	La max	S	f	YBC252 YBC251			YBG105 YBG102 YB9320 YBG205 YBG202 YBG302				YD101 YD201	
	<b>ZTBD02002-MM</b>	0.2	13	2	0,02-0,07						● ● ○		
	<b>ZTED02503-MM</b>	0.3	17	2.5	0,03-0,1						●		
	<b>ZTFD0303-MM</b>	0.3	17	3	0,04-0,13						●		
	<b>ZTGD0404-MM</b>	0.4	22	4	0,06-0,18						●		
	<b>ZTHD0504-MM</b>	0.4	22	5	0,08-0,23						●		
	<b>ZTKD0608-MM</b>	0.8	22	6	0,12-0,27						●		
	<b>ZTLD0808-MM</b>	0.8	28	8	0,13-0,29	○					● ○		

● Ex stock ○ On demand

HC<sup>1</sup> Coated carbide  
HW Uncoated carbide

Tool holders

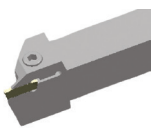
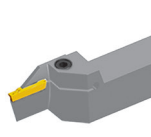
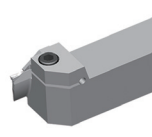
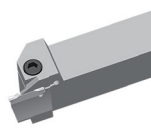
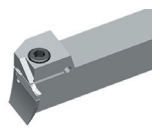
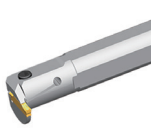
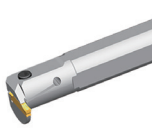
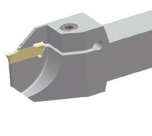
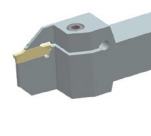
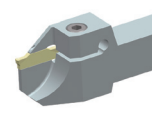
QE*D*R/L	QF*D*R/L-H	QF*D*LL-H	QF*D*RR-H	QF*D*R/L-L	*-QBDR/L	C***-Q*DR/L
						
A425	A434	A436	A436	A439	A444	A444
QE*D*R/L-DGC	QE*D*R/L-DGSC	QE*D*R/L-SC				
						
A446	A448	A449				

System code > A398

Grade selection > A394

Technical info > A501

Cutting data > A456



A

Turning

B

Milling

C

Drilling

D

Technical Information



E











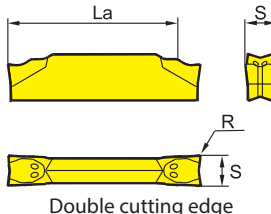







Index

**A**

Turning

## Parting inserts

-  Ideal machining conditions
-  Normal machining conditions
-  Unfavourable machining conditions

Parting & grooving insert (double sided)						HC <sup>1</sup> (CVD)		HC <sup>1</sup> (PVD)			HW						
 <p>Double cutting edge</p>						<b>P</b>	 					   					
						<b>M</b>					   						
						<b>K</b>											
						<b>N</b>										 	
						<b>S</b>							   				
						<b>H</b>											
	ISO	R±0.1	La max	S±0.10	f	YBC252 YBC251		YBG105 YBG102 YB9320 YBG205 YBG202 YBG302			YD101 YD201						
	<b>ZPED02502-MG</b>	0.2	17	2.5	0,03-0,1	●		●	○	●							
	<b>ZPFD0302-MG</b>	0.2	17	3	0,04-0,13	●		●	○	●							
	<b>ZPGD0402-MG</b>	0.2	22	4	0,07-0,18	●		●		○							
	<b>ZPHD0503-MG</b>	0.3	22	5	0,1-0,24				○	●							
	<b>ZPKD0604-MG</b>	0.4	22	6	0,12-0,29	○			○	●							

● Ex stock    ○ On demand

HC<sup>1</sup> Coated carbide  
HW Uncoated carbide

**B**

Milling

**C**

Drilling

**D**

Technical Information

**E**

Index

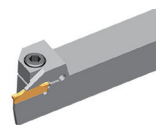
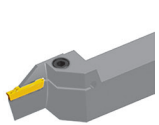
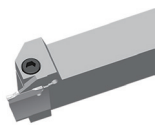
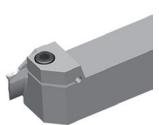
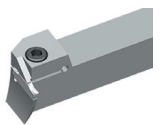
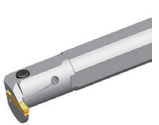
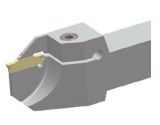
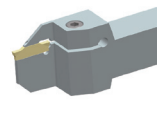
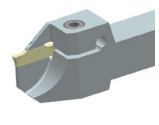
Tool holders						
<b>QE*D*R/L</b>	<b>QF*D*R/L-H</b>	<b>QF*D*RR-H</b>	<b>QF*D*LL-H</b>	<b>QF*D*R/L-L</b>	<b>C***-Q*DR/L</b>	<b>QE*D*R/L-DGC</b>
						
A425	A434	A436	A436	A439	A444	A446
<b>QE*D*R/L-DGSC</b>	<b>QE*D*R/L-SC</b>					
						
A448	A449					



System code > A398











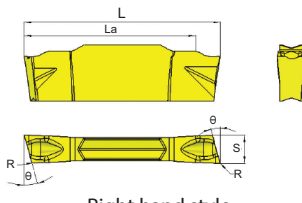







Grade selection > A394

Technical info > A501

Cutting data > A456

Parting inserts

-  Ideal machining conditions
-  Normal machining conditions
-  Unfavourable machining conditions

ZT** parting & grooving insert (double sided)								HC <sup>1</sup> (CVD)		HC <sup>1</sup> (PVD)			HW			
 <p>Right hand style</p>	<b>P</b>															
	<b>M</b>															
	<b>K</b>															
	<b>N</b>															
	<b>S</b>															
	<b>H</b>															
ISO	La max	L	S	θ	R	f	YBC252	YBC251	YBG105	YBG102	YB9320	YBG205	YBG202	YBG302	YD101	YD201
	<b>ZPED02502-MG-6L</b>	17	20	2.35	6°	0.2	0,03-0,08							●		
	<b>ZPED02502-MG-6R</b>	17	20	2.35	6°	0.2	0,03-0,08				●			●		
	<b>ZPED02502-MG-15L</b>	17	20	2.35	15°	0.2	0,03-0,05							○		
	<b>ZPED02502-MG-15R</b>	17	20	2.35	15°	0.2	0,03-0,05							○		
	<b>ZPFD0302-MG-6L</b>	17	20	2.85	6°	0.2	0,04-0,1				●			○	●	
	<b>ZPFD0302-MG-6R</b>	17	20	2.85	6°	0.2	0,04-0,1				●			○	○	
	<b>ZPFD0302-MG-15L</b>	17	20	2.85	15°	0.2	0,04-0,08							○	○	
	<b>ZPFD0302-MG-15R</b>	17	20	2.85	15°	0.3	0,04-0,08					●		○		

● Ex stock ○ On demand

HC<sup>1</sup> Coated carbide  
HW Uncoated carbide

Tool holders

QE\*D\*R/L

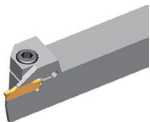

A425

System code > A398

Grade selection > A394

Technical info > A501

Cutting data > A456



A

Turning

B

Milling

C

Drilling

D

Technical Information



E











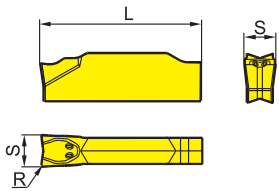

Index

**A**

Turning

## Parting inserts

-  Ideal machining conditions
-  Normal machining conditions
-  Unfavourable machining conditions

Parting & grooving insert (single sided)					HC <sup>1</sup> (CVD)		HC <sup>1</sup> (PVD)			HW	
 <p>Single cutting edge</p>	<b>P</b>										
	<b>M</b>										
	<b>K</b>										
	<b>N</b>										
	<b>S</b>										
	<b>H</b>										

**B**

Milling



ISO	R±0.1	S±0.10	f	YBC252		YBC251		YBG105		YBG102		YBG320		YBG205		YBG202		YBG302		YD101		YD201	
				●	○	●	○	●	○	●	○	●	○	●	○	●	○	●	○	●	○	●	○
ZPES02502-MG	0.2	2.5	0,03-0,1																				
ZPFS0302-MG	0.2	3	0,04-0,13	●																			
ZPGS0402-MG	0.2	4	0,07-0,18	○																			
ZPGS0402-MG-25	0.2	4	0,07-0,18																				
ZPHS0503-MG	0.3	5	0,1-0,24																				
ZPHS0503-MG-25	0.3	5	0,1-0,24																				
ZPKS0604-MG	0.4	6	0,12-0,29																				
ZPKS0604-MG-25	0.4	6	0,12-0,29																				

● Ex stock ○ On demand  
Single sided inserts only for parting blades

HC<sup>1</sup> Coated carbide  
HW Uncoated carbide

**C**

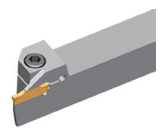
Drilling

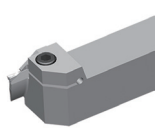
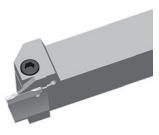
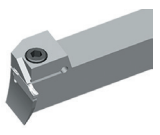
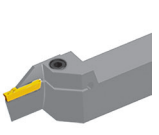
Tool holders					
QE*S*R/L	QZ**+QE**	QF*S*LL-H	QF*S*RR-H	QF*S*R/L-L	QF*S*R/L-H
					
A427	A432	A438	A438	A441	A442



**D**

Technical Information



















**E**

Index



-  Ideal machining conditions
-  Normal machining conditions
-  Unfavourable machining conditions

Parting inserts

Parting & grooving insert (single sided)							HC <sup>1</sup> (CVD)		HC <sup>1</sup> (PVD)			HW					
  Single cutting edge	<b>P</b>																
	<b>M</b>																
	<b>K</b>																
	<b>N</b>																
	<b>S</b>																
<b>H</b>																	
ISO	R±0.1	L	S±0.10	θ	f	YBC252	YBC251			YBG105	YBG102	YB9320	YBG205	YBG202	YBG302	YD101	YD201
	<b>ZPES02502-MG-6L</b>	0.2	19.9	2.5	6°	0,03-0,08						●					
	<b>ZPES02502-MG-6R</b>	0.2	19.9	2.5	6°	0,03-0,08						●					
	<b>ZPFS0302-MG-6L</b>	0.2	19.9	3	6°	0,04-0,1						●					
	<b>ZPFS0302-MG-6R</b>	0.2	19.9	3	6°	0,04-0,1						●					

● Ex stock    ○ On demand

Single sided inserts only for parting blades

HC<sup>1</sup> Coated carbide  
HW Uncoated carbide

Tool holders

QZ\*\*+QE\*\*



A432

System code > A398

Grade selection > A394

Technical info > A501

Cutting data > A456















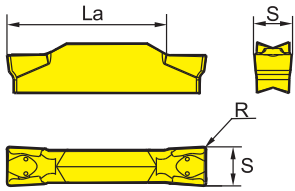







**A**

Turning

## Parting inserts

-  Ideal machining conditions
-  Normal machining conditions
-  Unfavourable machining conditions

Parting & grooving insert (double sided)					HC <sup>1</sup> (CVD)		HC <sup>1</sup> (PVD)			HW		
	<b>P</b>											
	<b>M</b>											
	<b>K</b>											
	<b>N</b>											
	<b>S</b>											
<b>H</b>												

**B**

Milling



ISO	R±0.1	La max	S±0.10	f	YBC252 YBC251		YBG105 YBG102 YB9320 YBG205 YBG202 YBG302					YD101 YD201					
																	
ZTED02503-MG		17	2.5	0,03-0,11													
ZTFD0303-MG		17	3	0,04-0,14													
ZTGD0402-MG		22	4	0,07-0,2													
ZTGD0404-MG		22	4	0,07-0,2													
ZTHD0504-MG		22	5	0,10-0,25													
ZTKD0604-MG		22	6	0,13-0,30													
ZTKD0608-MG		22	6	0,13-0,30													

● Ex stock    ○ On demand

HC<sup>1</sup> Coated carbide  
HW Uncoated carbide

**C**

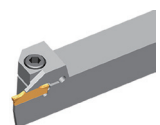
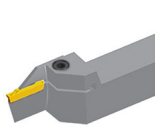
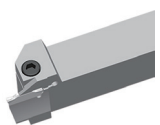
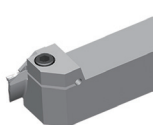
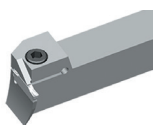
Drilling

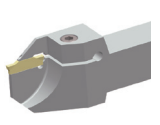
Tool holders						
QE*D*R/L	QF*D*R/L-H	QF*D*RR-H	QF*D*LL-H	QF*D*R/L-L	C***-Q*DR/L	QE*D*R/L-DGC
						
A425	A434	A436	A436	A439	A444	A446

**D**

Technical Information

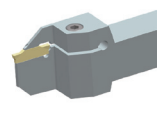
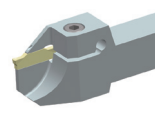
QE*D*R/L-DGSC	QE*D*R/L-SC
	
A448	A449

**E**



Index

System code > A398











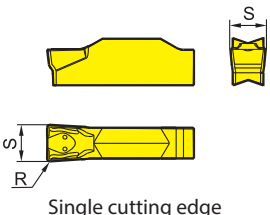







Grade selection > A394

Technical info > A501

Cutting data > A456





-  Ideal machining conditions
-  Normal machining conditions
-  Unfavourable machining conditions

Parting inserts

Parting & grooving insert (single sided)					HC <sup>1</sup> (CVD)		HC <sup>1</sup> (PVD)			HW		
	<b>P</b>											
	<b>M</b>											
	<b>K</b>											
	<b>N</b>											
	<b>S</b>											
	<b>H</b>											
ISO	R±0.1	S±0.10	f	YBC252 YBC251			YBG105 YBG102 YB9320 YBG205 YBG202 YBG302				YD101 YD201	
	<b>ZTHS0504-MG</b>	0.4	5	0,10-0,25				○	○	●		
	<b>ZTKS0608-MG</b>	0.8	6	0,13-0,30				○	●			

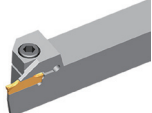
● Ex stock ○ On demand

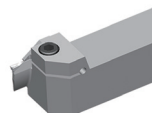
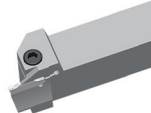
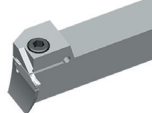
HC<sup>1</sup> Coated carbide  
HW Uncoated carbide

Tool holders					
<b>QE*S*/L</b>	<b>QZ**+QE**</b>	<b>QF*S*LL-H</b>	<b>QF*S*RR-H</b>	<b>QF*S*/L-L</b>	<b>QF*S*/L-H</b>
					
A427	A431	A438	A438	A441	A442

System code > A398

Grade selection > A394

Technical info > A501



Cutting data > A456











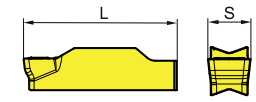
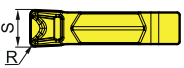









**A**

Turning

## Parting inserts

-  Ideal machining conditions
-  Normal machining conditions
-  Unfavourable machining conditions

Parting & grooving insert (single sided)						HC <sup>1</sup> (CVD)		HC <sup>1</sup> (PVD)			HW								
  Single cutting edge						<b>P</b>													
						<b>M</b>													
						<b>K</b>													
						<b>N</b>													
						<b>S</b>													
						<b>H</b>													
ISO						R±0.1	L	S±0.10	f	YBC252 YBC251			YBG105 YBG102 YB9320 YBG205 YBG202 YBG302	YD101 YD201					
	<b>ZTES02503-MM</b>					0.3	19.9	2.5	0,03-0,1										
	<b>ZTFS0303-MM</b>					0.3	19.9	3	0,04-0,13										
	<b>ZTGS0404-MM-25</b>					0.4	24.6	4	0,06-0,18										
	<b>ZTHS0504-MM-25</b>					0.4	24.6	5	0,08-0,23										
	<b>ZTKS0608-MM-25</b>					0.8	24.6	6	0,12-0,27										

● Ex stock    ○ On demand

HC<sup>1</sup> Coated carbide  
HW Uncoated carbide

**B**

Milling

**C**



Drilling

**D**

Technical Information

**E**

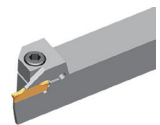
Index

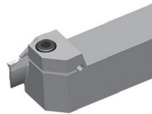
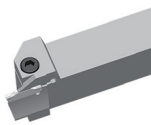
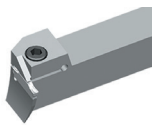
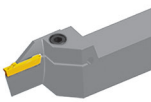
Tool holders					
QE*S*R/L	QZ**+QE**	QF*S*LL-H	QF*S*RR-H	QF*S*R/L-L	QF*S*R/L-H
					
A427	A432	A438	A438	A441	A442

System code > A398

Grade selection > A394

Technical info > A501

Cutting data > A456

Parting inserts

- Ideal machining conditions
- Normal machining conditions
- Unfavourable machining conditions

Parting & grooving insert (double sided)						HC <sup>1</sup> (CVD)		HC <sup>1</sup> (PVD)				HW					
						<b>P</b>											
						<b>M</b>											
						<b>K</b>											
						<b>N</b>											
						<b>S</b>											
						<b>H</b>											
ISO	La max	S±0.025	R±0.05	f	YBC252	YBC251	YBG105	YBG102	YB9320	YBG205	YBG202	YBG302	YD101	YD201			
ZTCD01002-EG	2.6	1	0.2	0,02-0,04								○					
ZTCD011502-EG	2.6	1.15	0.2	0,02-0,04								○					
ZTCD01202-EG	2.6	1.2	0.2	0,02-0,04								○					
ZTCD013802-EG	2.6	1.38	0.2	0,02-0,04								○					
ZTCD01402-EG	2.6	1.4	0.2	0,02-0,04								○					
ZTCD01500-EG	2.6	1.5	0	0,02-0,04								○					
ZTCD01502-EG	2.6	1.5	0.2	0,02-0,04								○					
ZTCD01503-EG	2.6	1.5	0.3	0,02-0,04							○						
ZTCD015503-EG	2.6	1.55	0.3	0,02-0,04								○					
ZTCD01602-EG	2.6	1.6	0.2	0,02-0,04								○					
ZTCD01702-EG	3.4	1.7	0.2	0,02-0,08								○					
ZTCD017503-EG	3.4	1.75	0.3	0,02-0,08								○					
ZTCD017602-EG	3.4	1.76	0.2	0,02-0,08							○						
ZTCD01802-EG	3.4	1.8	0.2	0,02-0,08								○					
ZTCD018502-EG	3.4	1.85	0.2	0,02-0,08								○					
ZTCD02000-EG	3.4	2	0	0,02-0,08								○					
ZTCD02002-EG	3.4	2	0.2	0,02-0,08								●					
ZTCD020503-EG	3.4	2.05	0.3	0,02-0,08								○					
ZTCD021502-EG	3.4	2.15	0.2	0,02-0,08								○					
ZTCD02302-EG	3.4	2.3	0.2	0,03-0,11								○					
ZTCD02303-EG	3.4	2.3	0.3	0,03-0,11								○					
ZTCD02402-EG	3.4	2.4	0.2	0,03-0,11								○					

● Ex stock ○ On demand

HC<sup>1</sup> Coated carbide  
HW Uncoated carbide

Tool holders

QECD

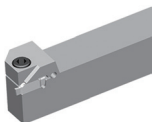

A428

System code > A398

Grade selection > A394

Technical info > A501



Cutting data > A456











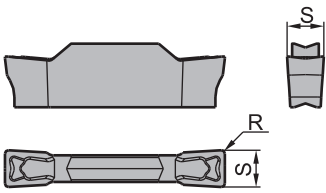







A

Turning

## Parting inserts

-  Ideal machining conditions
-  Normal machining conditions
-  Unfavourable machining conditions

Parting & grooving insert (double sided)					HC <sup>1</sup> (CVD)		HC <sup>1</sup> (PVD)					HW	
	<b>P</b>												
	<b>M</b>												
	<b>K</b>												
	<b>N</b>												
	<b>S</b>												
	<b>H</b>												

B

Milling

ISO	La max	S±0.025	R±0.05	f	YBC252 YBC251		YBG105 YBG102 YB9320 YBG205 YBG202 YBG302					YD101 YD201			
ZTED02502-EG	17	2.5	0.2	0,03-0,11											
ZTED026502-EG	17	2.65	0.2	0,03-0,11											
ZTED02702-EG	17	2.7	0.2	0,03-0,11											
ZTED02703-EG	17	2.7	0.3	0,03-0,11											
ZTED02802-EG	17	2.8	0.2	0,04-0,13											
ZTED02803-EG	17	2.8	0.3	0,04-0,13											
ZTED02804-EG	17	2.8	0.4	0,04-0,13											
ZTED02903-EG	17	2.9	0.3	0,04-0,13											
ZTFD03001-EG	17	3	0.1	0,04-0,13											
ZTFD03002-EG	17	3	0.2	0,04-0,13											
ZTFD03003-EG	17	3	0.3	0,04-0,13											
ZTFD03203-EG	17	3.2	0.3	0,04-0,13											
ZTFD0325024-EG	17	3.25	2.4	0,04-0,13											
ZTFD03302-EG	17	3.3	0.2	0,04-0,13											
ZTFD03303-EG	17	3.3	0.3	0,04-0,13											
ZTFD03403-EG	17	3.4	0.3	0,04-0,13											
ZTFD035-EG	17	3.5	0	0,04-0,13											
ZTGD039602-EG	22	3.96	0.2	0,07-0,18											
ZTGD04002-EG	22	4	0.2	0,07-0,18											
ZTGD04003-EG	22	4	0.3	0,07-0,18											
ZTGD04004-EG	22	4	0.4	0,07-0,18											
ZTGD04008-EG	22	4	0.8	0,07-0,18											
ZTGD04503-EG	22	4.5	0.3	0,07-0,18											
ZTGD04505-EG	22	4.5	0.5	0,07-0,18											
ZTGD04805-EG	22	4.8	0.5	0,1-0,24											
ZTHD05003-EG	22	5	0.3	0,1-0,24											
ZTHD05004-EG	22	5	0.4	0,1-0,24											
ZTHD05008-EG	22	5	0.8	0,1-0,24											
ZTHD05012-EG	22	5	0.12	0,1-0,24											
ZTHD05202-EG	22	5.2	0.2	0,1-0,24											
ZTHD052503-EG	22	5.25	0.3	0,1-0,24											
ZTHD05508-EG	22	5.5	0.8	0,1-0,24											

C

Drilling

D

Technical Information

E

Index

● Ex stock    ○ On demand



HC<sup>1</sup> Coated carbide  
HW Uncoated carbide

System code > A398











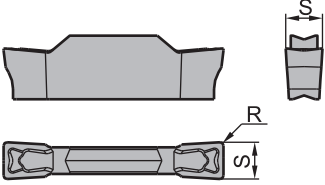





Grade selection > A394

Technical info > A501

Cutting data > A456

-  Ideal machining conditions
-  Normal machining conditions
-  Unfavourable machining conditions



**Parting inserts**

Parting & grooving insert (double sided)						HC <sup>1</sup> (CVD)		HC <sup>1</sup> (PVD)			HW	
	<b>P</b>											
	<b>M</b>											
	<b>K</b>											
	<b>N</b>											
	<b>S</b>											
	<b>H</b>											
ISO	La max	S±0.025	R±0.05	f	YBC252 YBC251			YBG105 YBG102 YB9320 YBG205 YBG202 YBG302			YD101 YD201	
	<b>ZTKD06004-EG</b>	22	6	0,4	0,12-0,29							
	<b>ZTKD06504-EG</b>	22	6,5	0,4	0,12-0,29							

● Ex stock    ○ On demand

HC<sup>1</sup> Coated carbide  
HW Uncoated carbide

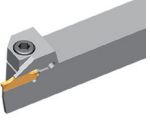
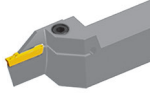
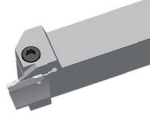
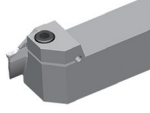
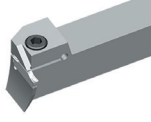
**Tool holders**

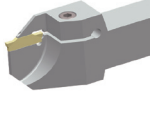
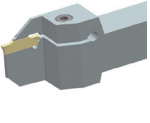
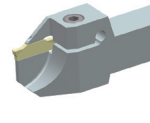
QE*D*R/L	QF*D*R/L-H	QF*D*RR-H	QF*D*LL-H	QF*D*R/L-L	C***-Q*DR/L	QE*D*R/L-DGC
						
A425	A434	A436	A436	A439	A444	A446
QE*D*R/L-DGSC	QE*D*R/L-SC					
						
A448	A449					

System code > A398

Grade selection > A394

Technical info > A501

Cutting data > A456



**A**

Turning

**B**

Milling

**C**

Drilling

**D**

Technical Information



**E**











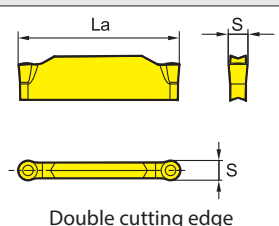



Index

**A**

Turning

## Parting inserts

-  Ideal machining conditions
-  Normal machining conditions
-  Unfavourable machining conditions

Parting & grooving insert (double sided)		HC <sup>1</sup> (CVD)		HC <sup>1</sup> (PVD)			HW		
 <p>Double cutting edge</p>	<b>P</b>								
	<b>M</b>								
	<b>K</b>								
	<b>N</b>								
	<b>S</b>								
<b>H</b>									

**B**

Milling

ISO	La max	S±0.10	f	YBC252		YBC251		YBG105		YBG102		YBG320		YBG205		YBG202		YBG302		YD101		YD201	
				●	○	●	○	●	○	●	○	●	○	●	○	●	○	●	○	●	○	●	○
	<b>ZRED025-MG</b>	17.5	2.5	0,03-0,11																			
	<b>ZRFD03-MG</b>	17	3	0,04-0,14																			
	<b>ZRGD04-MG</b>	21	4	0,07-0,2		○																	
	<b>ZRHD05-MG</b>	20	5	0,1-0,24																			○
	<b>ZRKD06-MG</b>	19	6	0,12-0,29																			

● Ex stock ○ On demand

HC<sup>1</sup> Coated carbide  
HW Uncoated carbide

**C**

Drilling

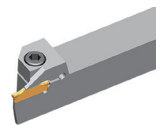
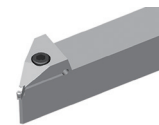
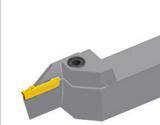
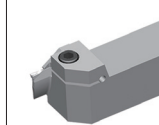
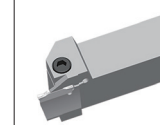
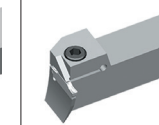
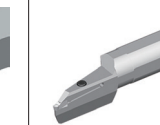
Tool holders						
QE*D*R/L	QX*D*	QF*D*R/L-H	QF*D*LL-H	QF*D*RR-H	QF*D*R/L-L	C*X-Q*DR/L
						
A425	A429	A434	A436	A436	A439	A443

C\*\*\*-Q\*DR/L

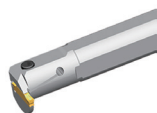

A444

**D**

Technical Information

**E**



Index

System code > A398











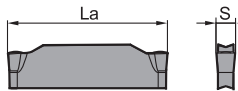
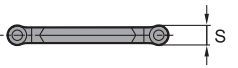







Grade selection > A394

Technical info > A501

Cutting data > A456

-  Ideal machining conditions
-  Normal machining conditions
-  Unfavourable machining conditions

Parting inserts

Parting & grooving insert (double sided)					HC <sup>1</sup> (CVD)		HC <sup>1</sup> (PVD)			HW				
  Double cutting edge	<b>P</b>													
	<b>M</b>													
	<b>K</b>													
	<b>N</b>													
	<b>S</b>													
	<b>H</b>													
ISO	La max	S±0.025	f	YBC252	YBC251		YBG105	YBG102	YB9320	YBG205	YBG202	YBG302	YD101	YD201
	ZRFD03-EG	17	3	0,04-0,14					●		○			
	ZRGD04-EG	21	4	0,07-0,2					●					
	ZRHD05-EG	20	5	0,1-0,24					●		○			
	ZRKD06-EG	19	6	0,12-0,29					○					

● Ex stock ○ On demand

HC<sup>1</sup> Coated carbide  
HW Uncoated carbide

Tool holders

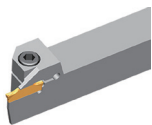
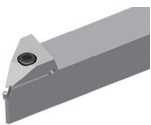
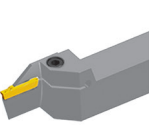
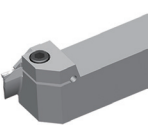
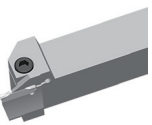
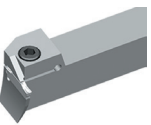
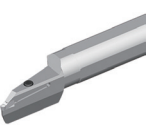
QE*D*R/L	QX*D*	QF*D*R/L-H	QF*D*LL-H	QF*D*RR-H	QF*D*R/L-L	C*X-Q*DR/L
						
A425	A429	A434	A436	A436	A439	A443

C\*\*\*-Q\*DR/L



System code > A398

Grade selection > A394

Technical info > A501

Cutting data > A456



**A**

Turning

## Parting inserts

- Ideal machining conditions
- ⊗ Normal machining conditions
- ⊗ Unfavourable machining conditions

Parting & grooving insert (single sided)							HC <sup>1</sup> (CVD)		HC <sup>1</sup> (PVD)			HW	
	<b>P</b>	⊗ ⊗							⊗ ⊗ ⊗ ⊗				
	<b>M</b>								⊗ ⊗ ⊗ ⊗				
	<b>K</b>												
	<b>N</b>											● ⊗	
	<b>S</b>								● ● ● ⊗ ⊗				
	<b>H</b>												

**B**

Milling

ISO	R±0.1	W±0.05	b	L	f	YBC252		YBC251		YBG105		YBG102		YB9320		YBG205		YBG202		YBG302		YD101		YD201	
<b>ZIMF304N-NM</b>	0.4	3	2.4	15.3	0,04-0,11					●															
<b>ZIMF406N-NM</b>	0.6	4	3.2	15.3	0,07-0,16					●	○														
<b>ZIMF506N-NM</b>	0.6	5	4	15.3	0,1-0,2					●	○														
<b>ZIMF608N-NM</b>	0.8	6	4	15.3	0,12-0,23					●	○														

● Ex stock    ○ On demand

HC<sup>1</sup> Coated carbide  
HW Uncoated carbide

**C**

Drilling

Tool holders

**QE\*S\*R/L-N**

A430

**D**

Technical Information

**E**



Index

System code > A398











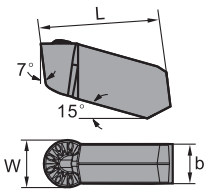







Grade selection > A394

Technical info > A501

Cutting data > A456

-  Ideal machining conditions
-  Normal machining conditions
-  Unfavourable machining conditions

**Parting inserts**

Parting & grooving insert (single sided)					HC <sup>1</sup> (CVD)		HC <sup>1</sup> (PVD)				HW			
	<b>P</b>													
	<b>M</b>													
	<b>K</b>													
	<b>N</b>													
	<b>S</b>													
	<b>H</b>													
ISO	W±0.05	b	L	f	YBC252	YBC251	YBG105	YBG102	YB9320	YBG205	YBG202	YBG302	YD101	YD201
	<b>ZIGQ3N-NM</b>	3	2.4	15.3	0,04-0,11			● ○						
	<b>ZIGQ4N-NM</b>	4	3.2	15.3	0,07-0,16			● ○						
	<b>ZIGQ5N-NM</b>	5	4	15.3	0,1-0,2			● ○						
	<b>ZIGQ6N-NM</b>	6	5	15.3	0,13-0,24			●						

● Ex stock ○ On demand

HC<sup>1</sup> Coated carbide  
HW Uncoated carbide

Tool holders

QE\*S\*R/L-N

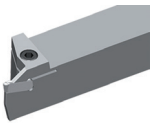

A430

System code > A398

Grade selection > A394

Technical info > A501

Cutting data > A456



**A**

Turning

**B**

Milling

**C**

Drilling

**D**

Technical Information



**E**











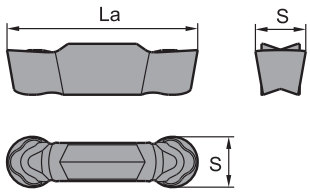





Index

**A**

Turning

## Parting inserts

-  Ideal machining conditions
-  Normal machining conditions
-  Unfavourable machining conditions

Parting & grooving insert (double sided)					HC <sup>1</sup> (CVD)		HC <sup>1</sup> (PVD)			HW				
	<b>P</b>													
	<b>M</b>													
	<b>K</b>													
	<b>N</b>													
	<b>S</b>													
	<b>H</b>													
ISO	La max	S±0.025	f	YBC252	YBC251		YBG105	YBG102	YB9320	YBG205	YBG202	YBG302	YD101	YD201
	<b>ZRKD06-LH</b>	19	6	0,12-0,23										○
	<b>ZRLD08-LH</b>	22	8	0,14-0,26										○

● Ex stock    ○ On demand

HC<sup>1</sup> Coated carbide  
HW Uncoated carbide

**B**

Milling

**C**

Drilling

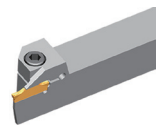
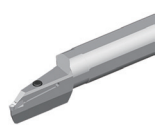
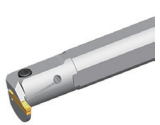
Tool holders		
QE*D*R/L	C*X-Q*DR/L	C***-Q*DR/L
		
A425	A443	A444

**D**

Technical Information

**E**



Index

System code > A398











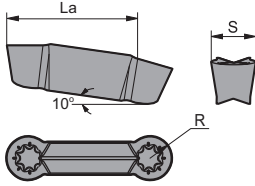







Grade selection > A394

Technical info > A501

Cutting data > A456

-  Ideal machining conditions
-  Normal machining conditions
-  Unfavourable machining conditions

**Parting inserts**

Parting & grooving insert (double sided)					HC <sup>1</sup> (CVD)		HC <sup>1</sup> (PVD)			HW		
	<b>P</b>											
	<b>M</b>											
	<b>K</b>											
	<b>N</b>											
	<b>S</b>											
	<b>H</b>											
ISO	La max	S±0.025	f	YBC252 YBC251			YBG105 YBG102 YB9320 YBG205 YBG202 YBG302				YD101 YD201	
	<b>ZILD08-LC</b>	22	8	0,14-0,26							○ ○	

● Ex stock    ○ On demand

HC<sup>1</sup> Coated carbide  
HW Uncoated carbide

**A**

Turning

**B**

Milling

**C**

Drilling

**D**

Technical Information

**E**

Index

System code > A398

Grade selection > A394

Technical info > A501

Cutting data > A456



## Triangular, tangential grooving inserts (straight edge)

# QC 22 R 300 – R 03

1      2      3      4      5      6

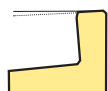

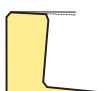
Series	Cutting edge length [mm]		Cutting direction	
	Code	I.C	Code	Description
	11	6,35	R	 Right
	16	9,525	L	 Left
22	12,70			

Groove width [mm]		Edge shape		Radius/Chamfer [mm]	
Code	Description	Code	Description	Code	Description
050	0,50	R	 Radius	005	0,05
100	1,00	C	 Chamfer	02	0,2
...	...			03	0,3
480	4,80			04	0,4

## Triangular, tangential grooving inserts (round edge)

# QC 22 R 300 – R

1      2      3      4      5

Series	Cutting edge length [mm]		Cutting direction		Groove width [mm]		Round
	Code	I.C	Code	Description	Code	Description	
	11	6,35	R	 Right	050	0,50	
	16	9,525	L	 Left	100	1,00	
22	12,70			...	...		
				480	4,80		

A

Turning

B

Milling

C

Drilling



D

Technical Information

E

Index

## Parting inserts

-  Ideal machining conditions
-  Normal machining conditions
-  Unfavourable machining conditions

QC\*\* turning/milling insert

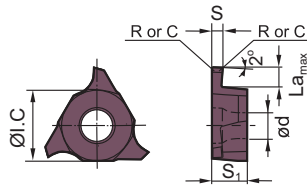

Right hand style

QC** turning/milling insert								HC <sup>1</sup> (CVD)		HC <sup>1</sup> (PVD)			HW				
								P	M	K	N	S	H				
ISO	La max	S±0.025	R/C	ØI.C	S1	ød	f	YBC252	YBC251	YBG105	YBG102	YB9320	YBG205	YBG202	YBG302	YD101	YD201
QC11R120-R02	1.5	1.2	0.2	6.35	3.18	2.8	0,02-0,03						●				
QC11L120-R02	1.5	1.2	0.2	6.35	3.18	2.8	0,02-0,03						●				
QC11R125-R02	1.5	1.25	0.2	6.35	3.18	2.8	0,02-0,03						●				
QC11L125-R02	1.5	1.25	0.2	6.35	3.18	2.8	0,02-0,03						●				
QC11R145-R02	1.5	1.45	0.2	6.35	3.18	2.8	0,02-0,05						●				
QC11L145-R02	1.5	1.45	0.2	6.35	3.18	2.8	0,02-0,05						●				
QC11R150-R02	1.5	1.5	0.2	6.35	3.18	2.8	0,02-0,05						●				
QC11L150-R02	1.5	1.5	0.2	6.35	3.18	2.8	0,02-0,05						●				
QC11R200-R02	2	2	0.2	6.35	3.18	2.8	0,02-0,06						●				
QC11L200-R02	2	2	0.2	6.35	3.18	2.8	0,02-0,06						●				
QC11R225-R02	2	2.25	0.2	6.35	3.18	2.8	0,02-0,06						○				
QC11L225-R02	2	2.25	0.2	6.35	3.18	2.8	0,02-0,06						○				
QC16R075-R01	2	0.75	0.1	9.525	3.18	4.4	0,02-0,03						○				
QC16L075-R01	2	0.75	0.1	9.525	3.18	4.4	0,02-0,03						○				
QC16R080-R01	2	0.8	0.1	9.525	3.18	4.4	0,02-0,03						○				
QC16R095-R01	2	0.95	0.1	9.525	3.18	4.4	0,02-0,03						○				
QC16L095-R01	2	0.95	0.1	9.525	3.18	4.4	0,02-0,03						○				
QC16L100-R01	2	1	0.1	9.525	3.18	4.4	0,02-0,03						○				
QC16R110-R01	2	1.1	0.1	9.525	3.18	4.4	0,02-0,03						○				
QC16L110-R01	2	1.1	0.1	9.525	3.18	4.4	0,02-0,03						● ○				
QC16R115-R04	2	1.15	0.4	9.525	3.18	4.4	0,02-0,03						○				
QC16R120-R01	2	1.2	0.1	9.525	3.18	4.4	0,02-0,03						○				
QC16L120-R01	2	1.2	0.1	9.525	3.18	4.4	0,02-0,03						○				
QC16R125-R02	2	1.25	0.2	9.525	3.18	4.4	0,02-0,03						○				
QC16L125-R02	2	1.25	0.2	9.525	3.18	4.4	0,02-0,03						●				
QC16R130-R02	2	1.3	0.2	9.525	3.18	4.4	0,02-0,06						○				
QC16L130-R02	2	1.3	0.2	9.525	3.18	4.4	0,02-0,06						○				
QC16R140-R02	2	1.4	0.2	9.525	3.18	4.4	0,02-0,06						○				
QC16R145-R02	2	1.45	0.2	9.525	3.18	4.4	0,02-0,06						●				
QC16L145-R02	2	1.45	0.2	9.525	3.18	4.4	0,02-0,06						●				
QC16R150-R02	2	1.5	0.2	9.525	3.18	4.4	0,02-0,06						●				
QC16L150-R02	2	1.5	0.2	9.525	3.18	4.4	0,02-0,06						○				
QC16R160-R02	2	1.6	0.2	9.525	3.18	4.4	0,02-0,06						●				
QC16L160-R02	2	1.6	0.2	9.525	3.18	4.4	0,02-0,06						●				

● Ex stock ○ On demand

HC<sup>1</sup> Coated carbide  
HW Uncoated carbide

System code > A416

Grade selection > A394

Technical info > A501

Cutting data > A456



A

Turning

B

Milling

C

Drilling

D

Technical Information



E

Index

A

Turning

## Parting inserts

-  Ideal machining conditions
-  Normal machining conditions
-  Unfavourable machining conditions

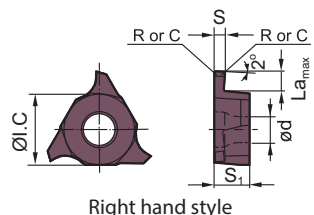

Right hand style

QC** turning/milling insert								HC <sup>1</sup> (CVD)		HC <sup>1</sup> (PVD)			HW				
								P									
								M									
								K									
								N									
								S									
								H									
ISO	La max	S±0.025	R/C	Øl.C	S1	ød	f	YBC252	YBC251	YBG105	YBG102	YB9320	YBG205	YBG202	YBG302	YD101	YD201
QC16R165-R02	2	1.65	0.2	9.525	3.18	4.4	0,02-0,06						○				
QC16L165-R02	2	1.65	0.2	9.525	3.18	4.4	0,02-0,06						○				
QC16R170-R02	2	1.7	0.2	9.525	3.18	4.4	0,02-0,06						○				
QC16L170-R02	2	1.7	0.2	9.525	3.18	4.4	0,02-0,06						○				
QC16R175-R02	2	1.75	0.2	9.525	3.18	4.4	0,02-0,07						●				
QC16L175-R02	2	1.75	0.2	9.525	3.18	4.4	0,02-0,06						○				
QC16R180-R02	2	1.8	0.2	9.525	3.18	4.4	0,02-0,07						○				
QC16R185-R02	2.5	1.85	0.2	9.525	3.18	4.4	0,02-0,07						●				
QC16L185-R02	2.5	1.85	0.2	9.525	3.18	4.4	0,02-0,07						○				
QC16R200-R02	2.5	2	0.2	9.525	3.18	4.4	0,02-0,07						●				
QC16L200-R02	2.5	2	0.2	9.525	3.18	4.4	0,02-0,07						●				
QC16L210-R02	2.5	2.1	0.2	9.525	3.18	4.4	0,02-0,07						○				
QC16L210-R05	2.5	2.1	0.5	9.525	3.18	4.4	0,02-0,07						○				
QC16R220-R02	2.5	2.2	0.2	9.525	3.18	4.4	0,02-0,07						○				
QC16L220-R02	2.5	2.2	0.2	9.525	3.18	4.4	0,02-0,07						○				
QC16R250-R02	2.5	2.5	0.2	9.525	3.18	4.4	0,02-0,08						● ○				
QC16L250-R02	2.5	2.5	0.2	9.525	3.18	4.4	0,02-0,08						●				
QC16R300-R02	3	3	0.2	9.525	3.18	4.4	0,03-0,11						●				
QC16L300-R02	3	3	0.2	9.525	3.18	4.4	0,03-0,11						●				
QC22L100-R02	2	1	0.2	12.7	4.76	5.5	0,02-0,03						○				
QC22R125-R02	2	1.25	0.2	12.7	4.76	5.5	0,02-0,03						●				
QC22L125-R02	2	1.25	0.2	12.7	4.76	5.5	0,02-0,03						○				
QC22R145-R02	2	1.45	0.2	12.7	4.76	5.5	0,02-0,06						○				
QC22L145-R02	2	1.45	0.2	12.7	4.76	5.5	0,02-0,06						○				
QC22R150-R02	3.5	1.5	0.2	12.7	4.76	5.5	0,02-0,06						○				
QC22L150-R02	3.5	1.5	0.2	12.7	4.76	5.5	0,02-0,06						○				
QC22R175-R02	3.5	1.75	0.2	12.7	4.76	5.5	0,02-0,06						●				
QC22L175-R02	3.5	1.75	0.2	12.7	4.76	5.5	0,02-0,06						○				
QC22R185-R02	3.5	1.85	0.2	12.7	4.76	5.5	0,02-0,07						●				
QC22L185-R02	3.5	1.85	0.2	12.7	4.76	5.5	0,02-0,07						○				
QC22R195-R02	3.5	1.95	0.2	12.7	4.76	5.5	0,02-0,07						○				
QC22R200-R02	3.5	2	0.2	12.7	4.76	5.5	0,02-0,07						○				
QC22L200-R02	3.5	2	0.2	12.7	4.76	5.5	0,02-0,07						○				
QC22R225-R02	3.5	2.25	0.2	12.7	4.76	5.5	0,02-0,07						○				

● Ex stock ○ On demand

HC<sup>1</sup> Coated carbide  
HW Uncoated carbide

B

Milling

C

Drilling

D

Technical Information

E

Index



System code > A416

Grade selection > A394









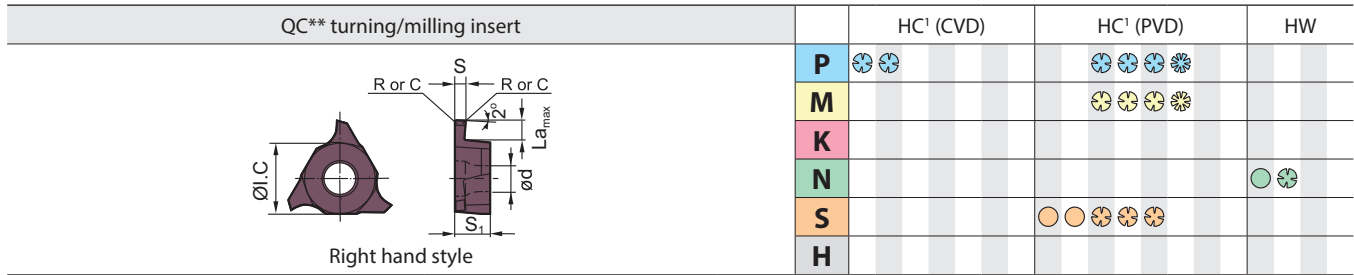









Technical info > A501

Cutting data > A456

## Parting inserts

-  Ideal machining conditions
-  Normal machining conditions
-  Unfavourable machining conditions



QC** turning/milling insert									HC <sup>1</sup> (CVD)		HC <sup>1</sup> (PVD)				HW					
									P											
									M											
									K											
									N											
									S											
									H											
ISO	La max	S±0.025	R/C	ØI.C	S1	ød	f		YBC252	YBC251		YBG105	YBG102	YB9320	YBG205	YBG202	YBG302	YD101	YD201	
QC22R230-R02	3.5	2.3	0.2	12.7	4.76	5.5	0,02-0,07								●					
QC22L230-R02	3.5	2.3	0.2	12.7	4.76	5.5	0,02-0,07								○					
QC22R250-R03	4	2.5	0.3	12.7	4.76	5.5	0,02-0,08								●					
QC22L250-R03	4	2.5	0.3	12.7	4.76	5.5	0,02-0,08								○					
QC22R265-R03	4	2.65	0.3	12.7	4.76	5.5	0,02-0,08								●					
QC22L265-R03	4	2.65	0.3	12.7	4.76	5.5	0,02-0,08								●					
QC22R280-R03	4	2.8	0.3	12.7	4.76	5.5	0,02-0,08								●					
QC22L280-R03	4	2.8	0.3	12.7	4.76	5.5	0,02-0,08								○					
QC22R300-R03	4	3	0.3	12.7	4.76	5.5	0,03-0,11								○					
QC22L300-R03	4	3	0.3	12.7	4.76	5.5	0,03-0,11								○					
QC22R320-R03	4	3.2	0.3	12.7	4.76	5.5	0,03-0,11								○					
QC22L320-R03	4	3.2	0.3	12.7	4.76	5.5	0,03-0,11								○					
QC22R330-R03	4	3.3	0.3	12.7	4.76	5.5	0,03-0,11								○					
QC22L330-R03	4	3.3	0.3	12.7	4.76	5.5	0,03-0,11								○					
QC22R350-R03	5	3.5	0.3	12.7	4.76	5.5	0,05-0,13								○					
QC22L350-R03	5	3.5	0.3	12.7	4.76	5.5	0,05-0,13								○					
QC22R400-R04	5	4	0.4	12.7	4.76	5.5	0,05-0,14								○					
QC22L400-R04	5	4	0.4	12.7	4.76	5.5	0,05-0,14								●					
QC22R430-R04	5	4.3	0.4	12.7	4.76	5.5	0,05-0,14								○					
QC22L430-R04	5	4.3	0.4	12.7	4.76	5.5	0,05-0,14								○	○				
QC22R450-R04	5	4.5	0.4	12.7	4.76	5.5	0,06-0,18								○					
QC22L450-R04	5	4.5	0.4	12.7	4.76	5.5	0,06-0,18								○				○	
QC22R480-R04	5	4.8	0.4	12.7	5.06	5.5	0,06-0,18								○					
QC22L480-R04	5	4.8	0.4	12.7	5.06	5.5	0,08-0,2								○					

● Ex stock   ○ On demand

HC<sup>1</sup> Coated carbide  
HW Uncoated carbide

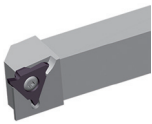
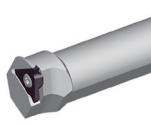

Tool holders	
GQCR/L	S***-QC**R/L
	
A453	A454



A







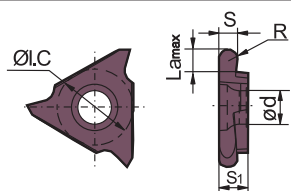













Turning

## Parting inserts

-  Ideal machining conditions
-  Normal machining conditions
-  Unfavourable machining conditions



Right hand style

QC** turning/milling insert								HC <sup>1</sup> (CVD)		HC <sup>1</sup> (PVD)			HW		
<b>P</b>															
<b>M</b>															
<b>K</b>															
<b>N</b>															
<b>S</b>															
<b>H</b>															

B

Milling

ISO	La max	S±0.025	R/C	Øl.C	S1	ød	f	YBC252 YBC251		YBG105 YBG102 YBG320 YBG205 YBG202 YBG302					YD101 YD201	
QC16R100R	2	1	0.5	12.7	3.18	4.4	0,02-0,03									
QC16R120R	2	1.2	0.6	12.7	3.18	4.4	0,02-0,03									
QC16R150R	2	1.5	0.75	12.7	3.18	4.4	0,02-0,06									
QC16R200R	2.5	2	1	12.7	3.18	4.4	0,02-0,07									
QC16L200R	2.5	2	1	12.7	3.18	4.4	0,02-0,07									
QC16R250R	2.5	2.5	1.25	12.7	3.18	4.4	0,02-0,08									
QC16L280R	2.5	2.8	1.4	12.7	3.18	4.4	0,02-0,08									
QC16R300R	2.5	3	1.5	12.7	3.18	4.4	0,03-0,11									
QC16L300R	2.5	3	1.5	12.7	3.18	4.4	0,03-0,11									
QC22R100R	2	1	0.5	12.7	4.76	5.5	0,02-0,03									
QC22L100R	2	1	0.5	12.7	4.76	5.5	0,02-0,03									
QC22R150R	3.5	1.5	0.75	12.7	4.76	5.5	0,02-0,06									
QC22L150R	3.5	1.5	0.75	12.7	4.76	5.5	0,02-0,06									
QC22R170R	3.5	1.7	0.85	12.7	4.76	5.5	0,02-0,06									
QC22R200R	3.5	2	1	12.7	4.76	5.5	0,02-0,07									
QC22L200R	3.5	2	1	12.7	4.76	5.5	0,02-0,07									
QC22R250R	4	2.5	1.25	12.7	4.76	5.5	0,02-0,08									
QC22L250R	4	2.5	1.25	12.7	4.76	5.5	0,02-0,08									
QC22R300R	4	3	1.5	12.7	4.76	5.5	0,03-0,11									
QC22L300R	4	3	1.5	12.7	4.76	5.5	0,03-0,11									
QC22R320R	4	3.2	1.6	12.7	4.76	5.5	0,03-0,11									
QC22R400R	5	4	2	12.7	4.76	5.5	0,05-0,14									
QC22L400R	5	4	2	12.7	4.76	5.5	0,05-0,14									

C

Drilling



D

Technical Information

● Ex stock    ○ On demand

HC<sup>1</sup> Coated carbide  
HW Uncoated carbide

### Tool holders

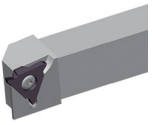
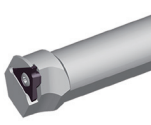
GQCR/L	S***-QC**R/L
	
A453	A454

E

Index

System code > A416

Grade selection > A394

Technical info > A501

Cutting data > A456



## External tool holders

**Q F G D 2525 R 22 (S) C – (130) (H)**

1 2 3 4 5 6 7 8 9 10 11

Holder for parting & grooving

1

Application	
Code	Description
E	External machining
F	Axial machining

2

Insert seat size [mm]	
Holder/cutting width	
Code	Description
A	1,5
B	2,0
E	2,5
F	3,0
G	4,0
H	5,0
K	6,0
L	8,0

3

No. of cutting edges	
Code	Description
S	Single
D	Double

4

Cross section of holder [mm] x [mm]

5

Type	
Code	Description
R	Right
L	Left
N	Right and left

6

Max. cutting depth [mm]

7

Serie	
Code	Description
S	Swiss turning holder
DG	Cut-off holder for greater grooving depths with reinforcement
DGS	Cut-off holder for greater grooving depths without reinforcement

8

With internal cooling

9

Min. diameter of work piece for first axial grooving [mm]

10

Cutting head	
Code	Description
H	0°
L	90°

11

Boring bars

**C 32 S – Q G D R 11 – 44**

1 2 3 4 5 6 7 8 9

Clamping system	Diameter [mm]	Length [mm]		Holder for grooving
		Code	Description	
1	2	Q	180	4
		R	200	
		S	250	
		X	320	
3		4		

Insert seat size [mm]		No. of cutting edges	
Holder/Cutting width		Code	Description
Code	Description	S	Single
B	2.0	D	Double
E	2.5		
F	3.0		
G	4.0		
H	5.0		
K	6.0		
L	8.0		
5		6	

Type		Max. cutting depth [mm]	Min. internal diameter of work piece [mm]
Code	Description		
R	Right	8	9
L	Left		
N	Right and left		
7			

**A**

Turning

**B**

Milling

**C**

Drilling

**D**

Technical Information

**E**

Index

## Blade

**Q E G D 32 N (-1)**

**1 2 3 4 5 6 7**



**1**

Application	
Code	Description
E	External machining

**2**

Insert seat size [mm]	
Holder/cutting width	
Code	Description
B	2,0
E	2,5
F	3,0
G	4,0
H	5,0
K	6,0
L	8,0

**3**

No. of cutting edges	
Code	Description
S	Single
D	Double

**4**

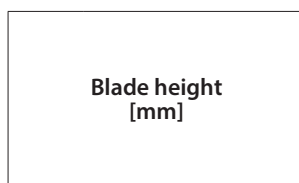

**5**

Type	
Code	Description
R	Right
L	Left
N	Right and left

**6**



**7**

## Clamping block

**QZ S 32 32**

**1 2 3 4**

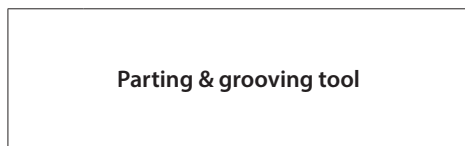

**1**

No. of cutting edges	
Code	Description
S	Single
D	Double

**2**

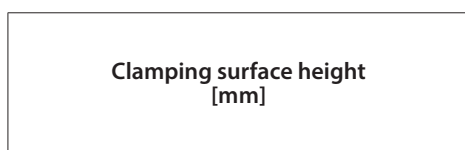

**3**

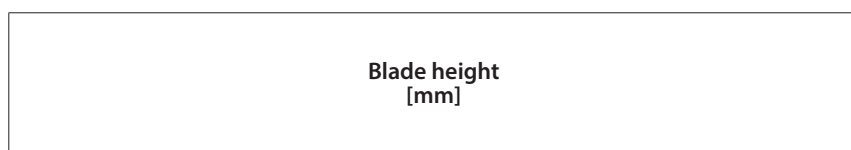

**4**

**Parting & grooving tool holder (external)**

QE\*\*R/L

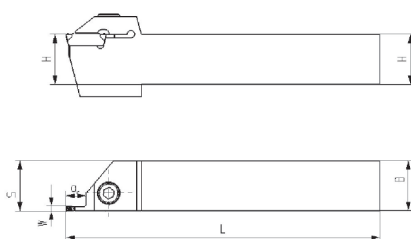
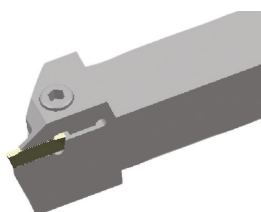



Article	*	Stock		Dimensions [mm]					Inserts
		R	L	HxB	L	S	W	ar <sub>max</sub>	
QEED1616R/L10	●	●	16x16	125	15	2.5	10	Z*ED**	
QEED1616R/L17	●	●	16x16	125	15	2.5	17	Z*ED**	
QEED2020R/L17	●	●	20x20	125	19	2.5	17	Z*ED**	
QEED2020R/L10	●	●	20x20	150	10	2.5	10	Z*ED**	
QEED2525R/L10	●	●	25x25	150	19	2.5	10	Z*ED**	
QEED2525R/L17	●	●	25x25	150	19	2.5	17	Z*ED**	
QEGD2020R/L13	●	●	20x20	140	18.5	4	13	Z*GD**	
QEGD2020R/L22	●	●	20x20	140	18.5	4	22	Z*GD**	
QEGD2525R/L13	●	●	25x25	150	23.5	4	13	Z*GD**	
QEGD2525R/L22	●	●	25x25	150	23.5	4	22	Z*GD**	
QEGD3232R/L13	●	●	32x32	170	30.5	4	13	Z*GD**	
QEGD3232R/L22	●	●	32x32	170	30.5	4	22	Z*GD**	
QEHD2525R/L13	●	●	25x25	150	23	5	13	Z*HD**	
QEHD2525R/L22	●	●	25x25	150	23	5	22	Z*HD**	
QEHD3232R/L13	●	●	32x32	170	30	5	13	Z*HD**	
QEHD3232R/L22	●	●	32x32	170	30	5	22	Z*HD**	
QEKD2525R/L13	●	●	25x25	150	22.6	6	13	Z*KD**	
QEKD2525R/L22	●	●	25x25	150	22.6	6	22	Z*KD**	
QEKD3232R/L13	●	●	32x32	170	29.6	6	13	Z*KD**	
QEKD3232R/L22	●	●	32x32	170	29.6	6	22	Z*KD**	

● Ex stock ○ On demand







\* With internal cooling

## Parting & grooving tool holder (external)

Spare parts

	Insert	Z*BD**	Z*ED**	Z*ED**	Z*FD**	Z*FD**	Z*GD**	Z*HD**	Z*KD**
	H	16-20	16	20-32	16	20-32	20-32	20-32	20-32
	Screw	GB70-85-M5×16 (4.0 Nm)	GB70-85-M5×20 (4.0 Nm)	GB70-85-M6×20 (7.0 Nm)	GB70-85-M5×20 (4.0 Nm)	GB70-85-M6×20 (7.0 Nm)	GB70-85-M6×20 (7.0 Nm)	GB70-85-M6×20 (7.0 Nm)	GB70-85-M6×20 (7.0 Nm)
	Wrench	WH40L	WH40L	WH50L	WH40L	WH50L	WH50L	WH50L	WH50L

Insert

						
A399	A400	A401	A404	A407	A410	A411



A414

System code > A422

Grade selection > A394

Technical info > A501

Cutting data > A456

**Parting & grooving tool holder (external)**

QE\*SN30

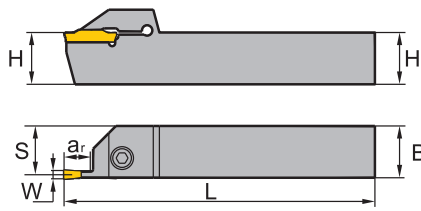
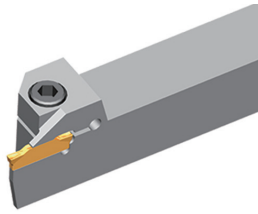

Article	*	Stock	Dimensions [mm]					Inserts
			HxB	L	S	W	ar <sub>max</sub>	
QEHS2525N30		●	25x25	150	12.5	5	30	Z*HS**
QEHS3232N30		●	32x32	170	16	5	30	Z*HS**
QEKS2525N30		○	25x25	150	12.5	6	30	Z*Ks**
QEKS3232N30		○	32x32	170	16	6	30	Z*Ks**

● Ex stock ○ On demand

\* With internal cooling

Spare parts			
	Insert	Z*HS**	Z*Ks**
	H	25-32	25-32
	Screw	GB70-85-M6x20 (7.0 Nm)	GB70-85-M6x20 (7.0 Nm)
	Wrench	WH50L	WH50L

Insert		
A402	A405	A406

System code > A422

Grade selection > A394

Technical info > A501

Cutting data > A456



A

Turning

B

Milling

C

Drilling

D

Technical Information

E

Index



## Parting & grooving tool holder (external)

QECDR/L

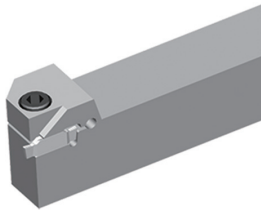

Right hand style

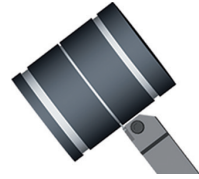
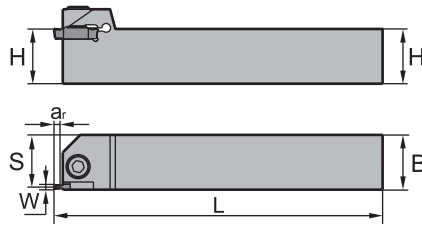

Article	*	Stock		Dimensions [mm]					Inserts
		R	L	HxB	L	S	W	ar <sub>max</sub>	
QECD1616R/L025		○	○	16x16	125	14.75		2.5	Z*CD**
QECD2020R/L025		○	○	20x20	125	18.75		2.5	Z*CD**
QECD2525R/L025		○	○	25x25	150	23.75		2.5	Z*CD**

● Ex stock ○ On demand

\* With internal cooling

### Spare parts

	Insert	Z*CD**	Z*CD**
	H	16	20-32
	Screw	GB70-85-M5×20 (4.0 Nm)	GB70-85-M6×20 (7.0 Nm)
	Wrench	WH40L	WH50L

Insert



A407

System code > A422

Grade selection > A394

Technical info > A501

Cutting data > A456

A

Turning

B

Milling

C

Drilling

D

Technical Information

E

Index

**Parting & grooving tool holder (external)**

QX\*DR/L

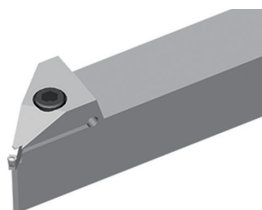

Right hand style

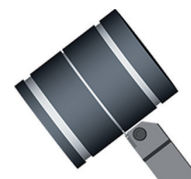
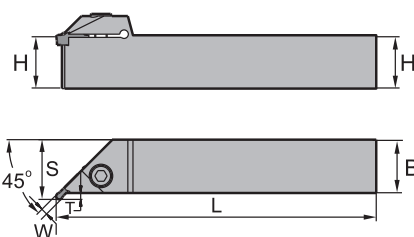

Article	*	Stock		Dimensions [mm]					Inserts
		R	L	HxB	L	S	W	ar <sub>max</sub>	
QXFD2020R/L03-45		○	○	20x20	125	23	3	3	Z*FD**
QXFD2525R/L03-45		●	●	25x25	150	28	3	3	Z*FD**
QXFD3232R/L03-45		○	○	32x32	170	35	3	3	Z*FD**
QXGD2020R/L03-45		○	○	20x20	125	23	4	3	Z*GD**
QXGD2525R/L03-45		○	○	25x25	150	28	4	3	Z*GD**
QXGD3232R/L03-45		○	○	32x32	170	35	4	3	Z*GD**
QXHD2020R/L04-45		○	○	20x20	125	24	5	4	Z*HD**
QXHD2525R/L04-45		○	○	25x25	150	29	5	4	Z*HD**
QXHD3232R/L04-45		○	○	32x32	170	36	5	4	Z*HD**
QXKD2020R/L04-45		○	○	20x20	125	24	6	4	Z*KD**
QXKD2525R/L04-45		○	○	25x25	150	29	6	4	Z*KD**
QXKD3232R/L04-45		○	○	32x32	170	36	6	4	Z*KD**

● Ex stock ○ On demand

\* With internal cooling

Spare parts

	Insert	Z*FD**	Z*GD**	Z*HD**	Z*KD**
	H	20-32	20-32	20-32	20-32
	Screw	GB70-85-M6x20 (7.0 Nm)	GB70-85-M6x20 (7.0 Nm)	GB70-85-M6x20 (7.0 Nm)	GB70-85-M6x20 (7.0 Nm)
	Wrench	WH50L	WH50L	WH50L	WH50L

Insert

A410	A411

## Parting & grooving tool holder (external)

QE\*SR/L

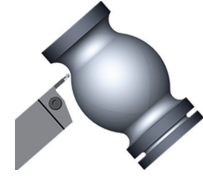
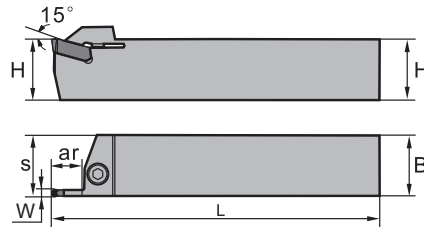
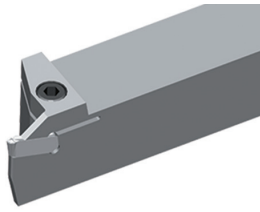



Right hand style

Article	*	Stock		Dimensions [mm]					Inserts
		R	L	HxB	L	S	W	ar <sub>max</sub>	
QEFS2525R/L12-3N		○	○	25x25	150	25.3	3	12	ZI**
QEGS2525R/L12-4N		○	○	25x25	150	25.3	4	12	ZI**
QEHS2525R/L12-5N		○	○	25x25	150	25.4	5	12	ZI**
QEKS2525R/L12-6N		○	○	25x25	150	25.4	6	12	ZI**
QEFS3232R/L22-3N		○	○	32x32	170	32.3	3	22	ZI**
QEGS3232R/L22-4N		○	○	32x32	170	32.3	4	22	ZI**
QEHS3232R/L22-5N		○	○	32x32	170	32.4	5	22	ZI**
QEKS3232R/L22-6N		○		32x32	170	32.4	6	22	ZI**



● Ex stock ○ On demand

\* With internal cooling

### Spare parts

	Insert	ZI**
	<b>H</b>	<b>25-32</b>
	Screw	GB70-85-M6x20 (7.0 Nm)
	Wrench	WH50L

### Insert

	
A412	A413

System code > A422

Grade selection > A394

Technical info > A501

Cutting data > A456

**Parting blade for external machining**

QE\*S\*\*N

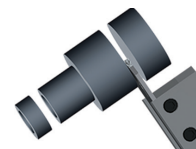
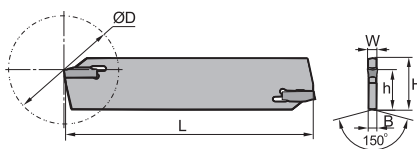
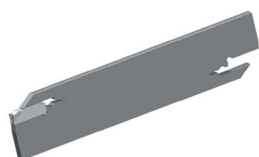

Article	*	Stock	Dimensions [mm]						Inserts
			H	L	h	B	W	ØDmax	
QEES26N	●		26	110	19	2	2.5	60	ZPES**
QEES32N	●		32	150	24.6	2	2.5	100	ZPES**
QEFS26N	●		26	110	19	2.4	3	60	ZPFS**
QEFS32N	●		32	150	24.6	2.4	3	100	ZPFS**
QEGS26N	●		26	110	19	3.2	4	70	ZPGS**
QEGS32N	●		32	150	24.6	3.2	4	120	ZPGS**
QEHS26N	●		26	110	19	4	5	70	ZPHS**
QEHS32N	●		32	150	24.6	4	5	120	ZPHS**
QEKs26N	●		26	110	19	5	6	70	ZPKS**
QEKs32N	●		32	150	24.6	5	6	120	ZPKS**

● Ex stock    ○ On demand

\* With internal cooling

Spare parts						
	Insert	ZPES**	ZPFS**	ZPGS**	ZPHS**	ZPKS**
	H	26-32	26-32	26-32	26-32	26-32
	Wrench	W50RL	W50RL	W50RL	W50RL	W50RL

Insert			
A402	A403	A405	A406

System code > A422

Grade selection > A394

Technical info > A501

Cutting data > A456



**A**

## Parting blade for external machining

QE\*S\*\*N-1

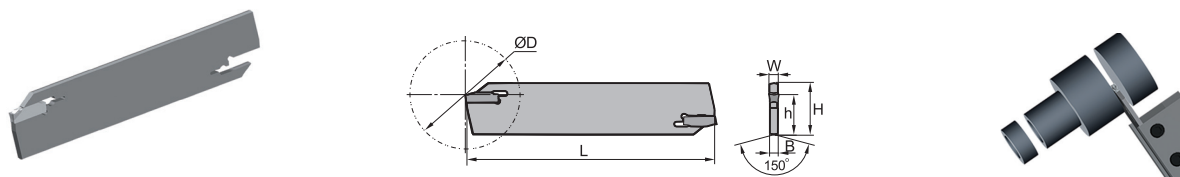

Turning

**B**

Article	*	Stock	Dimensions [mm]						Inserts
			H	L	h	B	W	ØDmax	
QEES26N-1	●		26	110	19	2	2.5	60	ZPES**
QEES32N-1	●		32	150	24.6	2	2.5	100	ZPES**
QEFS26N-1	●		26	110	19	2.4	3	60	ZPFS**
QEFS32N-1	●		32	150	24.6	2.4	3	100	ZPFS**
QEGS26N-1	●		26	110	19	3.2	4	70	ZPGS**
QEGS32N-1	●		32	150	24.6	3.2	4	120	ZPGS**

Milling

**C**

● Ex stock   ○ On demand

\* With internal cooling

Only compatible with clamping blocks of commercially available systems from other manufacturers.

Drilling

Spare parts				
	Insert	ZPES**	ZPFS**	ZPGS**
	H	26-32	26-32	26-32
	Wrench	W50X	W50X	W50X

W50X key must be ordered as an option.

**D**

Insert		
A402	A403	A406

Technical Information

**E**

Index

System code > A422

Grade selection > A394

Technical info > A501

Cutting data > A456

### Clamping block (external)

QZS\*

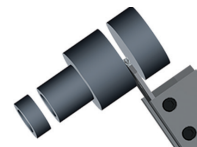
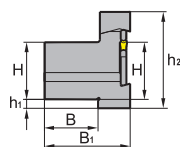
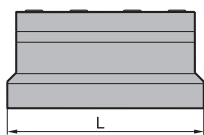
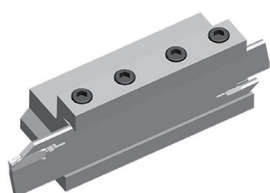

Article	*	Stock	Dimensions [mm]						Inserts
			H	L	h <sub>1</sub>	h <sub>2</sub>	B	B <sub>1</sub>	
QZS2026		●	20	86	10	46.6	19	38	QE**26
QZS2526		●	25	86	5	46.6	23	42	QE**26
QZS3226		○	32	86	3	51.6	30	48	QE**26
QZS2032		●	20	110	13	50	19	38	QE**32
QZS2532		●	25	110	8	50	23	42	QE**32
QZS3232		●	32	110	5	54	30	48	QE**32

● Ex stock ○ On demand

\* With internal cooling

Spare parts			
	Insert	QE**26	QE**32
	H	20-32	20-32
	Clamp	QZC26	QZC32
	Screw	GB70-85-M6×20 (7.0 Nm)	GB70-85-M6×20 (7.0 Nm)
	Wrench	W50RL	W50RL

A

Turning

B

Milling

C

Drilling

D

Technical  
Information

E

Index

## Parting & grooving tool holder (axial)

QF\*\*R/L

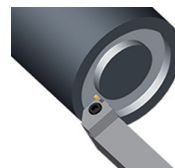
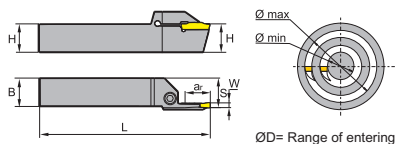
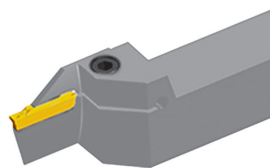

Left hand style

Article	*	Stock		Dimensions [mm]						Inserts
		R	L	HxB	L	S	W	ar <sub>max</sub>	ØD (min-max)	
QFFD2020R/L7-48H	○	○	20x20	150	21	3	7	48-66	Z*FD**	
QFFD2020R/L7-60H	○	○	20x20	150	21	3	7	60-80	Z*FD**	
QFFD2020R/L7-74H	○	○	20x20	150	21	3	7	74-110	Z*FD**	
QFFD2020R/L7-100H	○	○	20x20	150	21	3	7	100-150	Z*FD**	
QFFD2020R/L10-48H	○	○	20x20	150	21	3	10	48-66	Z*FD**	
QFFD2020R/L10-60H	○	○	20x20	150	21	3	10	60-80	Z*FD**	
QFFD2020R/L10-74H	○	○	20x20	150	21	3	10	74-110	Z*FD**	
QFFD2020R/L10-100H	○	○	20x20	150	21	3	10	100-150	Z*FD**	
QFFD2525R/L10-48H	●	●	25x25	150	26	3	10	48-66	Z*FD**	
QFFD2525R/L10-60H	●	●	25x25	150	26	3	10	60-80	Z*FD**	
QFFD2525R/L10-74H	●	●	25x25	150	26	3	10	74-110	Z*FD**	
QFFD2525R/L10-100H	●	●	25x25	150	26	3	10	100-150	Z*FD**	
QFFD2525R/L17-48H	●	●	25x25	150	26	3	17	48-66	Z*FD**	
QFFD2525R/L17-60H	●	●	25x25	150	26	3	17	60-80	Z*FD**	
QFFD2525R/L17-74H	●	●	25x25	150	26	3	17	74-110	Z*FD**	
QFFD2525R/L17-100H	●	●	25x25	150	26	3	17	100-150	Z*FD**	
QFGD2020R/L10-52H	○	○	20x20	150	21	4	10	52-72	Z*GD**	
QFGD2020R/L10-64H	○	○	20x20	150	21	4	10	64-100	Z*GD**	
QFGD2020R/L10-90H	○	○	20x20	150	21	4	10	90-140	Z*GD**	
QFGD2020R/L10-130H	○	○	20x20	150	21	4	10	130-230	Z*GD**	
QFGD2020R/L15-52H	○	○	20x20	150	21	4	15	52-72	Z*GD**	
QFGD2020R/L15-64H	○	○	20x20	150	21	4	15	64-100	Z*GD**	
QFGD2020R/L15-90H	○	○	20x20	150	21	4	15	90-140	Z*GD**	
QFGD2020R/L15-130H	○	○	20x20	150	21	4	15	130-230	Z*GD**	
QFGD2525R/L13-52H	●	●	25x25	150	26	4	13	52-72	Z*GD**	
QFGD2525R/L13-64H	●	●	25x25	150	26	4	13	64-100	Z*GD**	
QFGD2525R/L13-90H	●	●	25x25	150	26	4	13	90-140	Z*GD**	
QFGD2525R/L13-130H	●	●	25x25	150	26	4	13	130-230	Z*GD**	
QFGD2525R/L22-52H	●	●	25x25	150	26	4	22	52-72	Z*GD**	
QFGD2525R/L22-64H	●	●	25x25	150	26	4	22	64-100	Z*GD**	
QFGD2525R/L22-90H	●	●	25x25	150	26	4	22	90-140	Z*GD**	
QFGD2525R/L22-130H	●	●	25x25	150	26	4	22	130-230	Z*GD**	
QFHD2525R/L13-58H	●	●	25x25	150	26	5	13	58-96	Z*HD**	
QFHD2525R/L13-86H	●	●	25x25	150	26	5	13	86-140	Z*HD**	
QFHD2525R/L13-130H	●	●	25x25	150	26	5	13	130-200	Z*HD**	
QFHD2525R/L13-185H	●	●	25x25	150	26	5	13	185-400	Z*HD**	

System code > A422

Grade selection > A394



Technical info > A501







Cutting data > A456

Article	*	Stock		Dimensions [mm]						Inserts
		R	L	HxB	L	S	W	ar <sub>max</sub>	ØD (min-max)	
QFHD2523R/L16-44H		○		25x23	150		5	16	44-52	Z*HD**
QFHD2525R/L22-58H		●	●	25x25	150	26	5	22	58-96	Z*HD**
QFHD2525R/L22-86H		●	●	25x25	150	26	5	22	86-140	Z*HD**
QFHD2525R/L22-130H		●	●	25x25	150	26	5	22	130-200	Z*HD**
QFHD2525R/L22-185H		●	●	25x25	150	26	5	22	185-400	Z*HD**
QFKD2525R/L13-60H		●	●	25x25	150	26	6	13	60-100	Z*KD**
QFKD2525R/L13-88H		○	●	25x25	150	26	6	13	88-180	Z*KD**
QFKD2525R/L13-160H		●	●	25x25	150	26	6	13	160-400	Z*KD**
QFKD2525R/L20-45H			○	25x25	150		6	20	45-90	Z*KD**
QFKD2525R/L22-60H		●	●	25x25	150	26	6	22	60-100	Z*KD**
QFKD2525R/L22-88H		●	●	25x25	150	26	6	22	88-180	Z*KD**
QFKD2525R/L22-160H		●	●	25x25	150	26	6	22	160-400	Z*KD**
QFKD2525R/L30-88H		●		25x25	150		6	30	88-180	Z*KD**

● Ex stock ○ On demand

\* With internal cooling

Spare parts					
	Insert	Z*FD**	Z*GD**	Z*HD**	Z*KD**
	H	20-25	20-25	20-25	20-25
	Screw	GB70-85-M6×20 (7.0 Nm)	GB70-85-M6×20 (7.0 Nm)	GB70-85-M6×20 (7.0 Nm)	GB70-85-M6×20 (7.0 Nm)
	Wrench	W50RL	W50RL	W50RL	W50RL

Insert					
					
A399	A400	A404	A407	A410	A411

System code > A422

Grade selection > A394

Technical info > A501

Cutting data > A456



## Parting & grooving tool holder (axial)

QF\*\*RR/LL

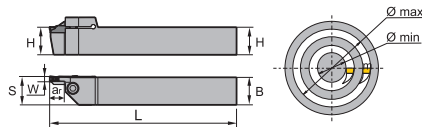
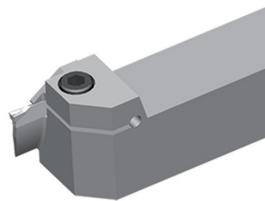

LL Version

Article	*	Stock		Dimensions [mm]						Inserts
		R	L	HxB	L	S	W	ar <sub>max</sub>	ØD (min-max)	
QFFD2020LL10-48H		○		20x20	150	21	3	10	48-66	Z*FD**
QFFD2020RR10-48H		○		20x20	150	21	3	10	48-66	Z*FD**
QFFD2020RR10-60H		○		20x20	150	21	3	10	60-80	Z*FD**
QFFD2020RR10-74H		○		20x20	150	21	3	10	74-110	Z*FD**
QFFD2525LL10-48H			●	25x25	150	26	3	10	48-66	Z*FD**
QFFD2525RR10-48H		○		25x25	150	26	3	10	48-66	Z*FD**
QFFD2525LL10-60H			○	25x25	150	26	3	10	60-80	Z*FD**
QFFD2525RR10-60H		○		25x25	150	26	3	10	60-80	Z*FD**
QFFD2525LL10-74H			○	25x25	150	26	3	10	74-110	Z*FD**
QFFD2525RR10-74H		○		25x25	150	26	3	10	74-110	Z*FD**
QFFD2525LL10-100H			○	25x25	150	26	3	10	100-150	Z*FD**
QFFD2525RR10-100H		○		25x25	150	26	3	10	100-150	Z*FD**
QFFD2525LL17-48H			●	25x25	150	26	3	17	48-66	Z*FD**
QFFD2525RR17-48H		○		25x25	150	26	3	17	48-66	Z*FD**
QFFD2525LL17-60H			○	25x25	150	26	3	17	60-80	Z*FD**
QFFD2525RR17-60H		○		25x25	150	26	3	17	60-80	Z*FD**
QFFD2525LL17-74H			○	25x25	150	26	3	17	74-110	Z*FD**
QFFD2525RR17-74H		○		25x25	150	26	3	17	74-110	Z*FD**
QFFD2525LL17-100H			○	25x25	150	26	3	17	100-150	Z*FD**
QFFD2525RR17-100H		○		25x25	150	26	3	17	100-150	Z*FD**
QFGD2020LL10-52H			○	20x20	150	21	4	10	52-72	Z*GD**
QFGD2020RR10-52H		○		20x20	150	21	4	10	52-72	Z*GD**
QFGD2020LL15-52H			○	20x20	150	26	4	15	52-72	Z*GD**
QFGD2020RR15-52H		○		20x20	150	26	4	15	52-72	Z*GD**
QFGD2020LL15-90H			○	20x20	150	26	4	15	90-140	Z*GD**
QFGD2020RR15-90H		○		20x20	150	26	4	15	90-140	Z*GD**
QFGD2020RR15-130H		○		20x20	150	26	4	15	130-230	Z*GD**
QFGD2525RR13-52H			●	25x25	150	21	4	13	52-72	Z*GD**
QFGD2525LL13-64H			●	25x25	150	21	4	13	64-100	Z*GD**
QFGD2525RR13-64H		○		25x25	150	21	4	13	64-100	Z*GD**
QFGD2525LL13-130H			●	25x25	150	26	4	13	130-230	Z*GD**
QFGD2525RR13-130H		○		25x25	150	21	4	13	130-230	Z*GD**
QFGD2525LL22-52H			○	25x25	150	26	4	22	52-72	Z*GD**
QFGD2525RR22-52H		○		25x25	150	26	4	22	52-72	Z*GD**
QFGD2525LL22-64H			○	25x25	150	26	4	22	64-100	Z*GD**

System code > A422

Grade selection > A394

Technical info > A501



Cutting data > A456

Article	*	Stock		Dimensions [mm]						Inserts 
		R	L	HxB	L	S	W	ar <sub>max</sub>	ØD (min-max)	
QFGD2525RR22-64H	○			25x25	150	26	4	22	64-100	Z*GD**
QFGD2525LL22-90H		○		25x25	150	26	4	22	90-140	Z*GD**
QFGD2525RR22-90H	○			25x25	150	26	4	22	90-140	Z*GD**
QFGD2525LL22-130H		○		25x25	150	26	4	22	130-230	Z*GD**
QFGD2525RR22-130H	●			25x25	150	26	4	22	130-230	Z*GD**
QFHD2525LL13-130H		○		25x25	150	26	5	13	130-200	Z*HD**
QFHD2525RR13-130H	○			25x25	150	26	5	13	130-200	Z*HD**
QFHD2525RR13-185H	○			25x25	150	26	5	13	185-400	Z*HD**
QFHD2525LL22-58H		●		25x25	150	26	5	22	58-96	Z*HD**
QFHD2525RR22-58H	●			25x25	150	26	5	22	58-96	Z*HD**
QFHD2525RR22-86H	○			25x25	150	26	5	22	86-140	Z*HD**
QFHD2525LL22-130H		○		25x25	150	26	5	22	130-200	Z*HD**
QFHD2525RR22-130H	●			25x25	150	26	5	22	130-200	Z*HD**
QFHD2525LL22-185H		○		25x25	150	26	5	22	185-400	Z*HD**
QFHD2525RR22-185H	○			25x25	150	26	5	22	185-400	Z*HD**
QFKD2525RR13-60H	○			25x25	150	26	6	13	60-100	Z*KD**
QFKD2525RR13-88H	○			25x25	150	26	6	13	88-180	Z*KD**
QFKD2525RR15-50H	○			25x25	150		6	15	50-100	Z*KD**
QFKD2525RR22-60H	○			25x25	150	26	6	22	60-100	Z*KD**
QFKD2525LL22-88H		○		25x25	150	26	6	22	88-180	Z*KD**
QFKD2525RR22-88H	○			25x25	150	26	6	22	88-180	Z*KD**
QFKD2525LL22-160H		●		25x25	150	26	6	22	160-400	Z*KD**
QFKD2525RR22-160H	○			25x25	150	26	6	22	160-400	Z*KD**







● Ex stock ○ On demand

\* With internal cooling

Spare parts

	Insert	Z*FD**	Z*GD**	Z*HD**	Z*KD**
	H	20-25	20-25	20-25	20-25
	Screw	GB70-85-M6×20 (7.0 Nm)	GB70-85-M6×20 (7.0 Nm)	GB70-85-M6×20 (7.0 Nm)	GB70-85-M6×20 (7.0 Nm)
	Wrench	W50RL	W50RL	W50RL	W50RL

Insert

					
A399	A400	A404	A407	A410	A411

System code > A422

Grade selection > A394

Technical info > A501

Cutting data > A456

## Parting & grooving tool holder (axial)

QF\*SRR/LL

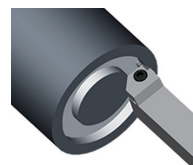
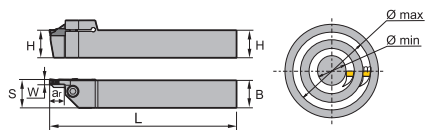
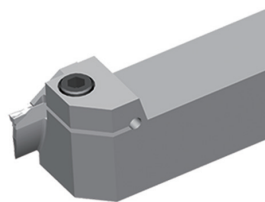

LL Version

Article	*	Stock		Dimensions [mm]						Inserts
		R	L	HxB	L	S	W	ar <sub>max</sub>	ØD (min-max)	
QFHS2525LL30-185H	●			25x25	150	26	5	30	185-400	Z*HS**
QFHS2525RR30-185H	○			25x25	150	26	5	30	185-400	Z*HS**
QFKS2525RR30-160H	○			25x25	150	26	6	30	160-400	Z*KS**
QFKS2525LL30-160H	○			25x25	150	26	6	30	160-400	ZT*S**

● Ex stock ○ On demand

\* With internal cooling

### Spare parts

	Insert	Z*HS**	Z*KS**	ZT*S**
	H	25	25	25
	Screw	GB70-85-M6x20 (7.0 Nm)	GB70-85-M6x20 (7.0 Nm)	GB70-85-M6x20 (7.0 Nm)
	Wrench	W50RL	W50RL	W50RL

### Insert

A402	A405	A406

System code > A422

Grade selection > A394

Technical info > A501

Cutting data > A456

**Parting & grooving tool holder (axial)**

QF\*DR/L

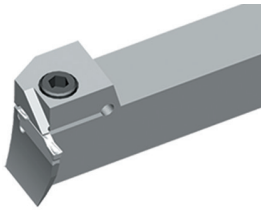

Right hand style

Article	*	Stock		Dimensions [mm]						Inserts
		R	L	HxB	L	S	W	ar <sub>max</sub>	ØD (min-max)	
QFFD2020R/L10-48L	○ ○			20x20	150	31.5	3	10	48-66	Z*FD**
QFGD2020R/L10-52L	○ ○			20x20	150	31.5	4	10	52-72	Z*GD**
QFFD2020R/L10-74L	● ○			20x20	150	31.5	3	10	74-110	Z*FD**
QFGD2020R/L10-90L	● ○			20x20	150	31.5	4	10	90-140	Z*GD**
QFFD2020R/L10-100L	○ ○			20x20	150	31.5	3	10	100-150	Z*FD**
QFGD2020R/L15-52L	○ ○			20x20	150	36.5	4	15	52-72	Z*GD**
QFFD2525R/L10-48L	● ●			25x25	150	36.5	3	10	48-66	Z*FD**
QFFD2525R/L10-60L	● ○			25x25	150	36.5	3	10	60-80	Z*FD**
QFFD2525R/L10-74L	○ ○			25x25	150	36.5	3	10	74-110	Z*FD**
QFFD2525R/L10-100L	○ ○			25x25	150	36.5	3	10	100-150	Z*FD**
QFGD2525R/L13-52L	○ ○			25x25	150	39.5	4	13	52-72	Z*GD**
QFKD2525R/L13-60L	○ ○			25x25	150	39.5	6	13	60-100	Z*KD**
QFGD2525R/L13-64L	○ ●			25x25	150	39.5	4	13	64-100	Z*GD**
QFGD2525R/L13-90L	○ ○			25x25	150	39.5	4	13	90-140	Z*GD**
QFGD2525R/L13-130L	○ ○			25x25	150	39.5	4	13	130-230	Z*GD**
QFFD2525R/L17-48L	○ ○			25x25	150	43.5	3	17	48-66	Z*FD**
QFFD2525R/L17-60L	○ ○			25x25	150	43.5	3	17	60-80	Z*FD**
QFFD2525R/L17-74L	○ ○			25x25	150	43.5	3	17	74-110	Z*FD**
QFFD2525R/L17-100L	● ○			25x25	150	43.5	3	17	100-150	Z*FD**
QFGD2525R/L22-52L	○ ○			25x25	150	48.5	4	22	52-72	Z*GD**
QFKD2525R/L22-60L	○ ●			25x25	150	48.5	6	22	60-100	Z*KD**
QFGD2525R/L22-64L	○ ○			25x25	150	48.5	4	22	64-100	Z*GD**
QFKD2525R/L22-88L	○ ●			25x25	150	48.5	6	22	88-180	Z*KD**
QFGD2525R/L22-90L	○ ○			25x25	150	48.5	4	22	90-140	Z*GD**
QFGD2525R/L22-130L	● ○			25x25	150	48.5	4	22	130-230	Z*GD**
QFFD2020R/L7-74L	○			20x20	150	28.5	3	7	74-110	Z*FD**
QFFD2020R/L10-60L	●			20x20	150	31.5	3	10	60-80	Z*FD**
QFGD2020R/L10-130L	●			20x20	150	31.5	4	10	130-230	Z*GD**
QFGD2020R/L15-64L	○			20x20	150	36.5	4	15	64-100	Z*GD**
QFGD2020R/L15-90L	○			20x20	150	36.5	4	15	90-140	Z*GD**
QFGD2020R/L15-130L	○			20x20	150	36.5	4	15	130-230	Z*GD**
QFHD2525R/L13-58L	○			25x25	150	39.5	5	13	58-96	Z*HD**
QFHD2525R/L13-86L	●			25x25	150	39.5	5	13	86-140	Z*HD**
QFHD2525R/L13-130L	○ ○			25x25	150	39.5	5	13	130-200	Z*HD**
QFHD2525R/L13-185L	○			25x25	150	39.5	5	13	185-400	Z*HD**
QFHD2525R/L22-58L	○ ○			25x25	150	48.5	5	22	58-96	Z*HD**

System code > A422

Grade selection > A394

Technical info > A501

Cutting data > A456



A

Turning

B

Milling

C

Drilling

D

Technical Information

E

Index

**A**

Turning



Article	*	Stock		Dimensions [mm]						Inserts 
		R	L	HxB	L	S	W	ar <sub>max</sub>	ØD (min-max)	
QFHD2525R/L22-86L		○	○	25x25	150	48.5	5	22	86-140	Z*HD**
QFHD2525R/L22-130L		○	○	25x25	150	48.5	5	22	130-200	Z*HD**
QFHD2525R/L22-185L		○	○	25x25	150	48.5	5	22	185-400	Z*HD**
QFKD2525R/L13-88L			○	25x25	150	39.5	6	13	88-180	Z*KD**

● Ex stock    ○ On demand

\* With internal cooling







**B**

Milling

Spare parts					
	Insert H	Z*FD** 20-25	Z*GD** 20-25	Z*HD** 20-25	Z*KD** 20-25
	Screw	GB70-85-M6x20 (7.0 Nm)	GB70-85-M6x20 (7.0 Nm)	GB70-85-M6x20 (7.0 Nm)	GB70-85-M6x20 (7.0 Nm)
	Wrench	W50RL	W50RL	W50RL	W50RL

**C**

Drilling

Insert					
					
A399	A400	A404	A407	A410	A411

**D**

Technical Information

**E**

Index

System code > A422

Grade selection > A394

Technical info > A501

Cutting data > A456

**Parting & grooving tool holder (axial)**

QFHSDR/L

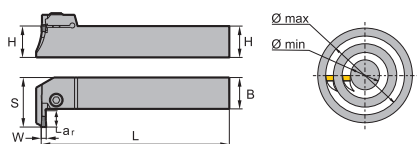
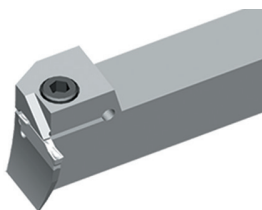



Right hand style

Article	*	Stock		Dimensions [mm]						Inserts
		R	L	HxB	L	S	W	ar <sub>max</sub>	ØD (min-max)	
QFHS2525R/L30-185L		○	○	25x25	150	56.5	5	30	185-400	Z*HS**

● Ex stock ○ On demand

\* With internal cooling

Spare parts

	Insert	Z*HS**
	H	25
	Screw	GB70-85-M6x20 (7.0 Nm)
	Wrench	W50RL

Insert

		
A402	A405	A406

System code > A422

Grade selection > A394

Technical info > A501

Cutting data > A456



## Parting & grooving tool holder (axial)

QF\*\*R/L

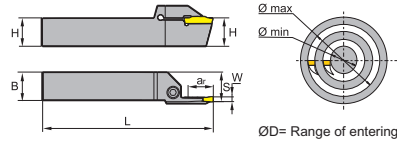
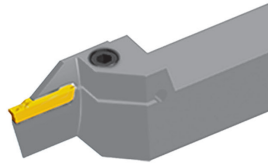

Left hand style

Article	*	Stock		Dimensions [mm]						Inserts
		R	L	HxB	L	S	W	ar <sub>max</sub>	ØD (min-max)	
QFHS2525R/L30-185H	•	•		25x25	150	26	5	30	185-400	Z*HS**
QFKS2525R/L30-160H	•	•		25x25	150	26	6	30	160-400	Z*KS**

• Ex stock    ○ On demand

\* With internal cooling

### Spare parts

	Insert	Z*HS**	Z*KS**
	H	25	25
	Screw	GB70-85-M6x20 (7.0 Nm)	GB70-85-M6x20 (7.0 Nm)
	Wrench	W50RL	W50RL

### Insert

A402	A405	A406

System code > A422

Grade selection > A394

Technical info > A501

Cutting data > A456

**Parting & grooving tool holder (external)**

C40X-Q\*DR/L

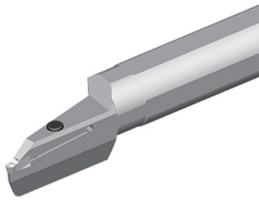

Right hand style

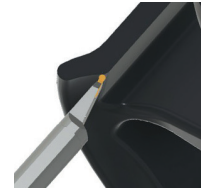
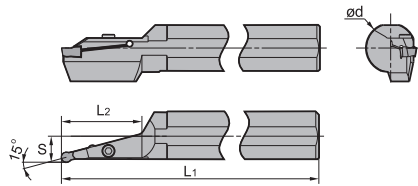

Article	*	Stock		Dimensions [mm]					Inserts
		R	L	ØD	ød	S	L <sub>1</sub>	L <sub>2</sub>	
C40X-QKDR/L60-15A		○	○	160	40	20	320	60	Z*KD**
C40X-QKDR/L75-15A		●	○	160	40	20	320	75	Z*KD**
C40X-QLDR/L65-15A		○	○	160	40	21	320	65	Z*LD**
C40X-QLDR/L80-15A		○	○	160	40	21	320	80	Z*LD**

● Ex stock ○ On demand

\* With internal cooling

Spare parts			
	Insert	Z*KD**	Z*LD**
	Ød	<b>32-40</b>	<b>32-40</b>
	Screw	GB70-85-M6×20 (7.0 Nm)	GB70-85-M6×20 (7.0 Nm)
	Wrench	WH50L	WH50L

Insert		
A410	A411	A414

System code > A422

Grade selection > A394

Technical info > A501

Cutting data > A456



## Parting & grooving tool holder (internal)

C\*\*\*-Q\*DR/L

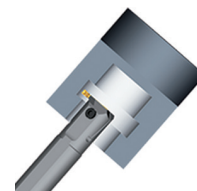
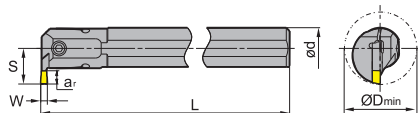
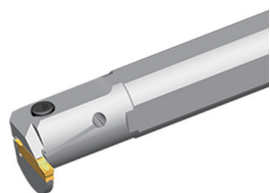

Article	*	Stock		Dimensions [mm]						Inserts
		R	L	ØDmin	ød	L	S	W	ar <sub>max</sub>	
C16M-QBDR/L04-20	● ○	●	○	20	16	150		2	4	Z*BD**
C20Q-QEDR/L05-27	● ●	●	●	27	20	180		2.5	5	Z*ED**
C25R-QEDR/L07-33	● ●	●	●	33	25	200		2.5	7	Z*ED**
C32S-QEDR/L09-42	● ●	●	●	42	32	250		2.5	9	Z*ED**
C20Q-QFDR/L05-27	● ●	●	●	27	20	0		3	5	Z*FD**
C25R-QFDR/L07-33	● ●	●	●	33	25	200		3	7	Z*FD**
C32S-QFDR/L09-42	● ●	●	●	42	32	250		3	9	Z*FD**
C25R-QGDR/L08-35	● ●	●	●	35	25	200		4	8	Z*GD**
C32S-QGDR/L11-44	● ●	●	●	44	32	250		4	11	Z*GD**
C40T-QGDR/L13-54	● ●	●	●	5	40	300		4	13	Z*GD**
C25R-QHDR/L08-35	● ●	●	●	35	25	200		5	8	Z*HD**
C32S-QHDR/L11-44	● ●	●	●	44	32	250		5	11	Z*HD**
C40T-QHDR/L13-54	● ●	●	●	54	40	300		5	13	Z*HD**
C25R-QKDR/L08-35	○ ●	○	●	35	25	200		6	8	Z*KD**
C32S-QKDR/L11-44	● ●	●	●	44	32	250		6	11	Z*KD**
C40T-QKDR/L13-54	● ●	●	●	54	40	300		6	13	Z*KD**

● Ex stock ○ On demand

\* With internal cooling

### Spare parts

	Insert	Z*BD**	Z*ED**	Z*ED**	Z*ED**	Z*FD**	Z*FD**	Z*FD**	Z*GD**	Z*GD**	Z*HD**	Z*HD**	Z*KD**	Z*KD**
		Ød	16	20	25	32-40	20	25	32-40	25	32-40	25	32-40	25
	Screw	GB70-85-M5x10 (4.0 Nm)	GB70-85-M4x12 (2.6 Nm)	GB70-85-M5x16 (4.0 Nm)	GB70-85-M6x20 (7.0 Nm)	GB70-85-M4x12 (2.6 Nm)	GB70-85-M5x16 (4.0 Nm)	GB70-85-M6x20 (7.0 Nm)	GB70-85-M5x16 (4.0 Nm)	GB70-85-M6x20 (7.0 Nm)	GB70-85-M5x16 (4.0 Nm)	GB70-85-M6x20 (7.0 Nm)	GB70-85-M5x16 (4.0 Nm)	GB70-85-M6x20 (7.0 Nm)
	Wrench	WH40L	WH30L	WH40L	WH50L	WH30L	WH40L	WH50L	WH40L	WH50L	WH40L	WH50L	WH40L	WH50L







System code > A422

Grade selection > A394

Technical info > A501

Cutting data > A456

**Parting & grooving tool holder (internal)**

Insert						
						
A399	A400	A404	A407	A410	A411	A414

**A**

Turning

**B**

Milling

**C**

Drilling

**D**

Technical  
Information

**E**

Index

System code > A422

Grade selection > A394

Technical info > A501

Cutting data > A456

## Parting & grooving tool holder (external)

QE\*\*R/L-DGC

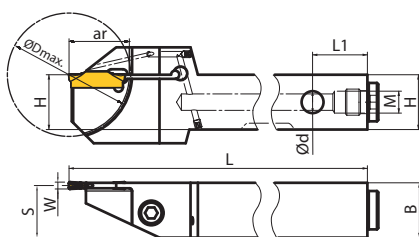
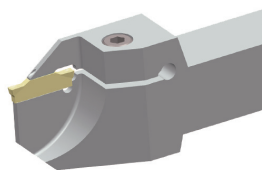

Article	*	Stock		Dimensions [mm]									Inserts
		R	L	HxB	ød	L	S	L <sub>1</sub>	W	ar <sub>max</sub>	ØD <sub>max</sub>	M	
QEBD1616R/L20-DGC	*	○	○	16x16	G1/8	96	15	20	2	20	40	G1/8	Z*BD**
QEBD1616R/L30-DGC	*	●	●	16x16	G1/8	105	15	20	2	30	60	G1/8	Z*BD**
QEBD2020R/L20-DGC	*	○	○	20x20	G1/8	111	19	20	2	20	40	G1/8	Z*BD**
QEBD2020R/L30-DGC	*	●	●	20x20	G1/8	120	19	20	2	30	60	G1/8	Z*BD**
QEBD2525R/L20-DGC	*	○	○	25x25	G1/8	126	24	20	2	20	40	G1/8	Z*BD**
QEBD2525R/L30-DGC	*	●	●	25x25	G1/8	135	24	20	2	30	60	G1/8	Z*BD**
QEED1616R/L20-DGC	*	○	○	16x16	G1/8	96	14.75	20	2.5	20	40	G1/8	Z*ED**
QEED1616R/L30-DGC	*	●	●	16x16	G1/8	105	14.75	20	2.5	30	60	G1/8	Z*ED**
QEED2020R/L20-DGC	*	○	○	20x20	G1/8	111	18.75	20	2.5	20	40	G1/8	Z*ED**
QEED2020R/L30-DGC	*	●	○	20x20	G1/8	120	18.75	20	2.5	30	60	G1/8	Z*ED**
QEED2525R/L20-DGC	*	○	○	25x25	G1/8	126	23.75	20	2.5	20	40	G1/8	Z*ED**
QEED2525R/L30-DGC	*	○	○	25x25	G1/8	135	23.75	20	2.5	30	60	G1/8	Z*ED**
Qefd1616R/L20-DGC	*	○	○	16x16	G1/8	96	14.5	20	3	20	40	G1/8	Z*FD**
Qefd1616R/L30-DGC	*	●	●	16x16	G1/8	105	14.5	20	3	30	60	G1/8	Z*FD**
Qefd2020R/L20-DGC	*	○	○	20x20	G1/8	111	18.5	20	3	20	40	G1/8	Z*FD**
Qefd2020R/L30-DGC	*	●	●	20x20	G1/8	120	18.5	20	3	30	60	G1/8	Z*FD**
Qefd2525R/L20-DGC	*	○	○	25x25	G1/8	126	23.5	20	3	20	40	G1/8	Z*FD**
Qefd2525R/L30-DGC	*	○	○	25x25	G1/8	135	23.5	20	3	30	60	G1/8	Z*FD**
QEGD1616R/L20-DGC	*	○	○	16x16	G1/8	96	14	20	4	20	40	G1/8	Z*GD**
QEGD1616R/L30-DGC	*	●	●	16x16	G1/8	105	14	20	4	30	60	G1/8	Z*GD**
QEGD2020R/L20-DGC	*	○	○	20x20	G1/8	111	18	20	4	20	40	G1/8	Z*GD**
QEGD2020R/L30-DGC	*	○	○	20x20	G1/8	120	18	20	4	30	60	G1/8	Z*GD**
QEGD2525R/L20-DGC	*	○	○	25x25	G1/8	126	23	20	4	20	40	G1/8	Z*GD**
QEGD2525R/L30-DGC	*	○	○	25x25	G1/8	135	23	20	4	30	60	G1/8	Z*GD**

● Ex stock ○ On demand

\* With internal cooling

### Spare parts

	Insert	Z*BD**	Z*ED**	Z*FD**	Z*GD**
		H	16-25	16-25	16-25
	Grub screw	PT1/8x4	PT1/8x4	PT1/8x4	PT1/8x4
	Screw	GB70-85-M5x20 (4.0 Nm)	GB70-85-M5x20 (4.0 Nm)	GB70-85-M5x20 (4.0 Nm)	GB70-85-M5x20 (4.0 Nm)
	Wrench	WH40L	WH40L	WH40L	WH40L
	Wrench	WH50L	WH50L	WH50L	WH50L





System code > A422

Grade selection > A394

Technical info > A501

Cutting data > A456

## Parting & grooving tool holder (external)

Insert			
			
A399	A400	A404	A407

**A**

Turning

**B**

Milling

**C**

Drilling

**D**

Technical  
Information

**E**

Index

System code > A422

Grade selection > A394

Technical info > A501

Cutting data > A456

## Parting & grooving tool holder (external)

QE\*\*R/L-DGSC

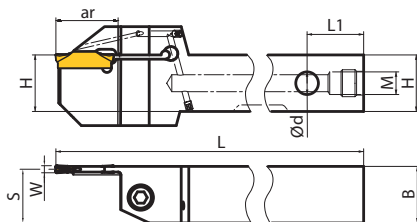
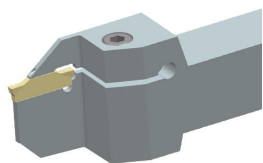

Article	*	Stock		Dimensions [mm]								Inserts
		R	L	HxB	ød	L	S	L <sub>1</sub>	W	ar <sub>max</sub>	M	
QEED1616R/L30-DGSC	*	●	●	16x16	G1/8	105	14.75	20	2.5	30	G1/8	Z*ED**
QEED2020R/L30-DGSC	*	●	○	20x20	G1/8	120	18.75	20	2.5	30	G1/8	Z*ED**
QEED2525R/L30-DGSC	*	○	○	25x25	G1/8	135	23.75	20	2.5	30	G1/8	Z*ED**
QEFD1616R/L30-DGSC	*	●	●	16x16	G1/8	105	14.5	20	3	30	G1/8	Z*FD**
QEFD2020R/L30-DGSC	*	○	○	20x20	G1/8	120	18.5	20	3	30	G1/8	Z*FD**
QEFD2525R/L30-DGSC	*	○	○	25x25	G1/8	135	23.5	20	3	30	G1/8	Z*FD**
QEGD1616R/L30-DGSC	*	○	○	16x16	G1/8	105	14	20	4	30	G1/8	Z*GD**
QEGD2020R/L30-DGSC	*	○	○	20x20	G1/8	120	18	20	4	30	G1/8	Z*GD**
QEGD2525R/L30-DGSC	*	○	○	25x25	G1/8	135	23	20	4	30	G1/8	Z*GD**
QEHD2525R/L30-DGSC	*	○	○	25x25	G1/8	135	22.5	20	5	30	G1/8	Z*HD**
QEKD2525R/L30-DGSC	*	○	○	25x25	G1/8	135	22	20	6	30	G1/8	Z*KD**

● Ex stock ○ On demand

\* With internal cooling

### Spare parts

Insert H	Z*ED**	Z*FD**	Z*GD**	Z*HD**	Z*KD**
	16-25	16-25	20-25	20-25	20-25
Grub screw	PT1/8x4	PT1/8x4	PT1/8x4	PT1/8x4	PT1/8x4
Screw	GB70-85-M5x20 (4.0 Nm)	GB70-85-M5x20 (4.0 Nm)	GB70-85-M5x20 (4.0 Nm)	GB70-85-M6x20 (7.0 Nm)	GB70-85-M6x20 (7.0 Nm)
Wrench	WH40L	WH40L	WH40L	WH50L	WH50L
Wrench	WH50L	WH50L	WH50L	WH50L	WH50L

### Insert

A399	A400	A404	A407

System code > A422

Grade selection > A394

Technical info > A501

Cutting data > A456

## Parting & grooving tool holder (external)

QE\*\*R/L-SC

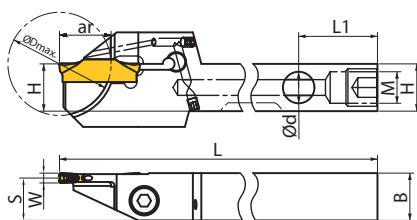
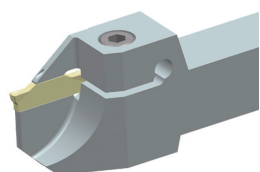

Article	*	Stock		Dimensions [mm]									Inserts
		R	L	HxB	ød	L	S	L <sub>1</sub>	W	ar <sub>max</sub>	ØD <sub>max</sub>	M	
QEAD1010R/L10-SC	*	○	○	10x10	G1/16	125	9	20	1.5	10	20	G1/16	Z*AD**
QEAD1212R/L13-SC	*	○	○	12x12	G1/8	125	12	20	1.5	13	26	G1/8	Z*AD**
QEAD1616R/L13-SC	*	○	○	16x16	G1/8	125	15	20	1.5	13	26	G1/8	Z*AD**
QEAD2020R/L13-SC	*	○	○	20x20	G1/8	125	19	20	1.5	13	26	G1/8	Z*AD**
QEBD1010R/L10-SC	*	○	○	10x10	G1/16	110	9	20	2	10	20	G1/16	Z*BD**
QEBD1212R/L13-SC	*	●	●	12x12	G1/8	110	11	20	2	13	26	G1/8	Z*BD**
QEBD1616R/L13-SC	*	●	●	16x16	G1/8	110	15	20	2	13	26	G1/8	Z*BD**
QEBD2020R/L13-SC	*	○	○	20x20	G1/8	110	19	20	2	13	26	G1/8	Z*BD**
QEED1010R/L10-SC	*	○	○	10x10	G1/16	110	8.75	20	2.5	10	20	G1/16	Z*ED**
QEED1212R/L13-SC	*	●	●	12x12	G1/8	110	10.75	20	2.5	13	26	G1/8	Z*ED**
QEED1616R/L17-SC	*	●	●	16x16	G1/8	110	14.75	20	2.5	17	34	G1/8	Z*ED**
QEED2020R/L17-SC	*	●	●	20x20	G1/8	110	18.75	20	2.5	17	34	G1/8	Z*ED**
Qefd1212R/L13-SC	*	●	●	12x12	G1/8	110	10.5	20	3	13	26	G1/8	Z*FD**
Qefd1616R/L17-SC	*	●	●	16x16	G1/8	110	14.5	20	3	17	34	G1/8	Z*FD**
Qefd2020R/L22-SC	*	●	●	20x20	G1/8	110	18.5	20	3	22	44	G1/8	Z*FD**

● Ex stock ○ On demand

\* With internal cooling

### Spare parts

Insert	H	Z*AD**	Z*AD**	Z*AD**	Z*AD**	Z*BD**	Z*BD**	Z*BD**	Z*ED**	Z*ED**	Z*ED**	Z*FD**	Z*FD**
		10	12	16	20	10	12	16-20	10	12	16-20	12	16-20
	Grub screw	PT1/16x6	PT1/8x4	PT1/8x4	PT1/8x4	PT1/16x6	PT1/8x4	PT1/8x4	PT1/16x6	PT1/8x4	PT1/8x4	PT1/8x4	PT1/8x4
	Screw	GB70-85-M4x12 (2.6 Nm)	GB70-85-M4x12 (2.6 Nm)	GB70-85-M4x14	GB70-85-M4x18	GB70-85-M4x12 (2.6 Nm)	GB70-85-M4x12 (2.6 Nm)	GB70-85-M6x20 (7.0 Nm)	GB70-85-M4x12 (2.6 Nm)	GB70-85-M4x12 (2.6 Nm)	GB70-85-M6x20 (7.0 Nm)	GB70-85-M4x12 (2.6 Nm)	GB70-85-M5x20 (4.0 Nm)
	Wrench	WH30L	WH30L	WH30L	WH30L	WH30L	WH30L	WH40L	WH30L	WH30L	WH40L	WH30L	WH40L
	Wrench	WH40L	WH50L	WH50L	WH50L	WH40L	WH50L	WH50L	WH40L	WH50L	WH50L	WH50L	WH50L

System code > A422

Grade selection > A394





Technical info > A501

Cutting data > A456



**A**

## Parting & grooving tool holder (external)

Insert			
			
A399	A400	A404	A407

Turning

**B**

Milling

**C**

Drilling

**D**

Technical  
Information

**E**

Index

System code > A422

Grade selection > A394

Technical info > A501

Cutting data > A456

## Accessoires

### Coolant hose



Article	Dimensions [mm]			Stock
	L	Th1	Th2	
HOSE G1/8-7/16/200BS	200	G1/8"-28 BSPP	G1/8"-28 BSPP	○
HOSE G1/8-7/16/300BS	300	G1/8"-28 BSPP	G1/8"-28 BSPP	○
HOSE G1/8-7/16/200BB	200	G1/8"-28 BSPP	G1/8"-28 BSPP	○
HOSE G1/8-7/16/300BB	300	G1/8"-28 BSPP	G1/8"-28 BSPP	○

● Ex stock ○ On demand

### Coolant connection

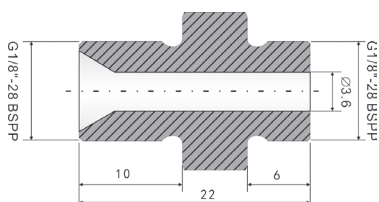

Article	Stock
NIPPLE G1/8- G1/8	○

● Ex stock ○ On demand

**A**

Turning

**B**

Milling

**C**

Drilling

**D**

Technical Information

**E**

Index



## External tool holders – QC series

# GQC R 20 20 K 22 – 15

1 2 3 4 5 6 7

Series	Type		Height [mm]		Width [mm]		Length [mm]	
	Code	Description	Code	Description	Code	Description	Code	Description
	R	Right	16	16	16	16	K	125
L	Left	20	20	20	20	M	150	
		25	25	25	25			

1

2

3

4

5

Cutting edge length [mm]	
Code	I.C
11	6,35
16	9,252
22	12,70

6

Cutting width range [mm]		
Code	Insert size	
15	0,5 ≤ S < 1,8 (QC16***)	1,0 ≤ S < 2,3 (QC22***)
25	1,8 ≤ S < 3,0 (QC16***)	2,3 ≤ S < 3,3 (QC22***)
35	–	3,3 ≤ S ≤ 4,8 (QC22***)

7

## Boring bars – QC series

# S 20 K – QC 16 15 R 25

1 2 3 4 5 6 7 8

Shank type	
Code	Material
S	Steel shank
C	Solid carbide shank
A	Solid carbide shank (IC)

1

Diameter [mm]	
Code	Description
16	16
20	20
25	25

2

Length [mm]	
Code	Description
H	100
K	125
M	150

3

Series	Cutting edge length [mm]	
	Code	I.C
	11	6,35
16	9,252	
22	12,70	

4

5

Cutting width range [mm]			
Code	Insert size		
15	0,5 ≤ S < 1,8 (QC11***)	0,5 ≤ S < 1,8 (QC16***)	1,0 ≤ S < 2,3 (QC22***)
25	1,8 ≤ S < 3,0 (QC11***)	1,8 ≤ S < 3,0 (QC16***)	2,3 ≤ S < 3,3 (QC22***)
35	–	–	3,3 ≤ S ≤ 4,8 (QC22***)

6

Cutting direction	
Code	Description
R	Right
L	Left

7

Starting diameter [mm]			
Code	∅	Code	∅
16	16	25	25
20	20	35	35

8

Grooving (external)

GQC\*\*R/L

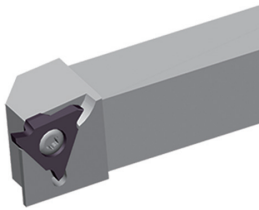

Right hand style

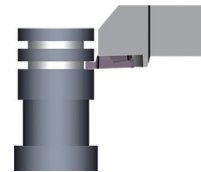
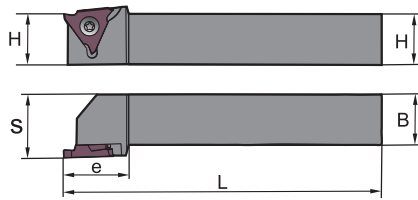



Article	*	Stock		Dimensions [mm]						Inserts
		R	L	H	L	S	e	B	Width	
GQCR/L1616K16-15	●	●	16	125	21	25.5	16	0.5-1.80	QC16R/L 050-180	
GQCR/L2020K16-15	○	●	20	125	25	25.5	20	0.5-1.80	QC16R/L 050-180	
GQCR/L2525M16-15	○	●	25	150	30	25.5	25	0.5-1.80	QC16R/L 050-180	
GQCR/L1616K16-25	●	●	16	125	21	25.5	16	1.8-3.0	QC16R/L 180-300	
GQCR/L2020K16-25	○	●	20	125	25	25.5	20	1.8-3.0	QC16R/L 180-300	
GQCR/L2525M16-25	○	●	25	150	30	25.5	25	1.8-3.0	QC16R/L 180-300	
GQCR/L2020K22-15	○	●	20	125	25	25.5	20	1.0-2.3	QC22R/L 100-230	
GQCR/L2525M22-15	○	●	25	150	30	25.5	25	1.0-2.3	QC22R/L 100-230	
GQCR/L2020K22-25	○	●	20	125	25	25.5	20	2.3-3.3	QC22R/L 230-330	
GQCR/L2525M22-25	○	●	25	150	30	25.5	25	2.3-3.3	QC22R/L 230-330	
GQCR/L2020K22-35	●	●	20	125	25	25.5	20	3.3-4.8	QC22R/L 330-480	
GQCR/L2525M22-35	●	●	25	150	30	25.5	25	3.3-4.8	QC22R/L 330-480	

● Ex stock ○ On demand

\* With internal cooling

Spare parts

	Insert	QC16R/L 050-180	QC16R/L 180-300	QC22R/L 100-230	QC22R/L 230-330	QC22R/L 330-480
	H	16-32	16-32	16-32	16-32	16-32
	Screw	I60M3.5×10 (2.7 Nm)	I60M3.5×10 (2.7 Nm)	I60M5×13 (6.7 Nm)	I60M5×13 (6.7 Nm)	I60M5×13 (6.7 Nm)
	Wrench (shim)	WT15IP	WT15IP	WT20IP	WT20IP	WT20IP

Insert



Medium Cut

A417

S\_QCR/L

S\*K-QC\*\*R/L

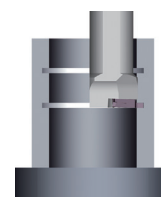
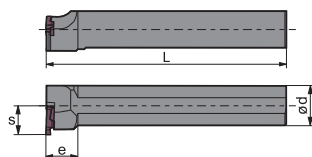
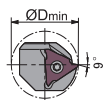
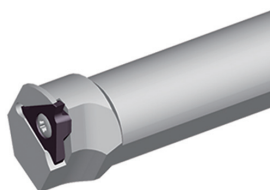

Right hand style

Article	*	Stock		Dimensions [mm]						Inserts
		R	L	ØDmin	ød	L	S	e	Width	
S16H-QC1115R/L20	•	•		21	16	100	11.5	12	0.5-1.80	QC11R/L 050-180
S20K-QC1115R/L16	•	•		16	20	125	11.1	40	0.5-1.80	QC11R/L 050-180
S16H-QC1125R/L20	•	•		21	16	100	11.5	12	1.8-3.0	QC11R/L 180-300
S20K-QC1125R/L16	○	○		16	20	125	11.1	40	1.8-3.0	QC11R/L 180-300
S20M-QC1615R/L25	○	•		26	20	150	12.5	15	0.5-1.80	QC16R/L 050-180
S20M-QC1625R/L25	•	•		26	20	150	12.5	15	1.8-3.0	QC16R/L 180-300
S25M-QC2215R/L35	•	•		35	25	150	18.2	15	1.0-2.3	QC22R/L 100-230
S25M-QC2225R/L35	•	•		35	25	150	18.2	20	2.3-3.3	QC22R/L 230-330
S25M-QC2235R/L35	○	•		35	25	150	18.2	20	3.3-4.8	QC22R/L 330-480

• Ex stock ○ On demand

\* With internal cooling

Right-hand tool holder for left-hand grooving insert.

Left-hand tool holder for right-hand grooving insert.

Spare parts

	Insert	QC11R/L 050-180	QC11R/L 180-300	QC16R/L 050-180	QC16R/L 180-300	QC22R/L 100-230	QC22R/L 230-330	QC22R/L 330-480
	ød	16-20	16-20	20	20	25	25	25
	Screw	I60M2.5×6.5 (1.0 Nm)	I60M2.5×6.5 (1.0 Nm)	I60M3.5×10 (2.7 Nm)	I60M3.5×10 (2.7 Nm)	I60M5×13 (6.7 Nm)	I60M5×13 (6.7 Nm)	I60M5×13 (6.7 Nm)
	Wrench (shim)	WT07IP	WT07IP	WT15IP	WT15IP	WT20IP	WT20IP	WT20IP

Insert



Medium Cut

A417

System code > A452

Grade selection > A394

Technical info > A501

Cutting data > A456



## Parting & grooving inserts

	Material group	Composition / structure / heat treatment		Brinell hardness HB	Machining group	Starting values for cutting speed vc [m/min]			
						HC (CVD)		HC (PVD)	
						YBC252	YBG102	YBG105	
<b>A</b> Turning	<b>P</b> Unalloyed steel	approx. 0,15 % C	annealed	125	1	190			
		approx. 0,45 % C	annealed	190	2	175			
		approx. 0,45 % C	tempered	250	3	145			
		approx. 0,75 % C	annealed	270	4	140			
		approx. 0,75 % C	tempered	300	5	135			
	<b>B</b> Milling	Low-alloyed steel		annealed	180	6	170		
				tempered	275	7	125		
				tempered	300	8	115		
				tempered	350	9	105		
	<b>C</b> Drilling	High-alloyed steel and high-alloyed tool steel		annealed	200	10	125		
			hardened and tempered	325	11	95			
<b>M</b> Stainless steel		ferritic/martensitic	annealed	200	12	165	165	170	
		martensitic	tempered	240	13	135	135	140	
		austenitic	quench hardened	180	14	155	155	160	
		austenitic-ferritic		230	15	135	135	140	
<b>K</b> Cast iron with spheroidal graphite		Grey cast iron	perlitic/ferritic		180	16	240		
			perlitic (martensitic)		260	17	185		
	Cast iron with spheroidal graphite	ferritic		160	18	220			
		perlitic		250	19	165			
	Malleable cast iron	ferritic		130	20	175			
		perlitic		230	21	165			
<b>N</b> Drilling	Aluminium wrought alloys	cannot be hardened		60	22				
		hardenable	hardened	100	23				
	Cast aluminium alloys	≤ 12% Si, cannot be hardened		75	24				
		≤ 12% Si, hardenable	hardened	90	25				
		> 12% Si, cannot be hardened		130	26				
	Copper and copper alloys (bronze/brass)	machining steel, PB> 1%		110	27				
		CuZn, CuSnZn		90	28				
CuSn, Pb-free copper, electrolytic copper		100	29						
<b>D</b> Technical Information	<b>S</b> Heat-resistant alloys	Fe-based alloys	annealed	200	30		95	100	
			hardened	280	31		50	50	
		Ni or Co bass	annealed	250	32		80	80	
			hardened	350	33		70	70	
			cast	320	34		70	70	
	Titanium alloys	pure titanium		R <sub>m</sub> 400	35		145	150	
α and β alloys		hardened	R <sub>m</sub> 1050	36		50	50		
<b>E</b> Index	<b>H</b> Hardened steel		hardened and tempered	55 HRC	37				
			hardened and tempered	60 HRC	38				
		Hard cast iron	cast	400	39				
		Hardened cast iron	hardened and tempered	55 HRC	40				
<b>X</b> Non-metallic materials	Non-metallic materials	Thermoplasts			41				
		Thermosetting plastics			42				
		Plastic, glass-fibre reinforced GFRP			43				
		Plastic, carbon fibre reinforced CFRP			44				
		Graphite			45				
		Wood			46				

Note: The given cutting values are guide values, which were determined under ideal conditions.  
The values have to be adapted in individual cases.  
For examples of material for cutting tool groups view page D11.

